

Needle Valve

Manifold Block and Bleed

MVBB, 20DBNV, Wellhead Gauge & Bleed/Vent Valves

Pressure to 30,000 psi (2070 bar)

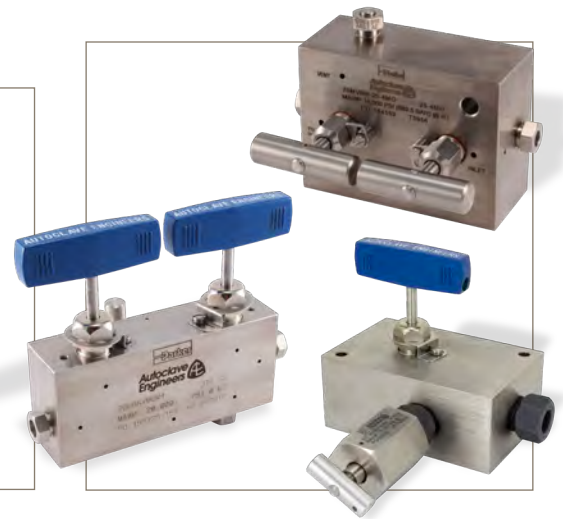

Principle of Operation:

Parker Autoclave Engineers Manifold Valves are available in compact Single and Double Block & Bleed manifold designs using Cone & Thread style and NPT connections. Designed for a maximum of 30,000 psi MAWP using high tensile strength UNS S31600/S31603 cold worked 316/316L Stainless Steel material as standard.

MVBB Single Block & Bleed Manifold Valve Features:

- MVBB Series valve design provides large valve performance in a small package
- Tubing sizes: 1/4" and 3/8" Pipe Size: 1/2" NPT
- Single Block & Bleed design

DBNV Double Block & Bleed Manifold Valve Features:

- Connection specific Non-Rotating Vee Stems matching material selection, (Rotating Stem Vent valve)
- Tubing Sizes from 1/4" to 3/4" Medium Pressure and 9/16" High Pressure (API Type III Connection)
- -423° to 1000°F (-252° to 540°C) Temperature Range

GV Series Wellhead Gauge Valve Features:

- One Inlet, 3 Outlet ports, standard using 9/16" HP (API Type III connection), other sizes available
- 30,000 psi MAWP capable, 20,000 psi MAWP NACE capable
- Use with BV Series Bleed Valve (below) in any outlet port to create Block and Bleed valve

BV Series Bleed/Vent Valve Features:

- 3/8" and 9/16" connections to match GV Series Gauge Valves above (API type III connection available)
- Vent port tapped (1/8" NPT) for plumbing to safe area
- Vent Valve can be rated to 30,000 psi in closed position, 15,000 psi in open position.

All Parker Autoclave Engineers products are designed in accordance with ASME B31.3 Chapter IX High Pressure Piping standards.



ENGINEERING YOUR SUCCESS.

MVBB Series: Pressures to 20,000 psi (1380 bar)

Single Block & Bleed Needle Type Manifold Valve

Principle of Operation:

Parker Autoclave Engineers series MVBB block and bleed needle valve is a two stem manifold valve providing an economical and convenient method of isolating and venting or pressurization when calibrating pressure transmitters and gauges.

The valve utilizes Parker Autoclave Engineers Mini Valve packing and stem design making it compact and easy to use. The valve can be surface or panel mounted for safe operation. Manifold style valves reduce the number of fittings and space required for installation.



MVBB Single Block & Bleed Manifold Valve Features:

- MVBB Series valve design provides large valve performance in a small package
- Tubing sizes: 1/4" and 3/8". Pipe size: 1/2" NPT
- UNS S31600/31603, CW 316/316L Stainless Steel body construction as standard. Additional Material options including NACE approved (SOG) materials are available.
- Rising stem/barstock body design
- Metal-to-metal seating achieves bubble-tight shut-off, longer stem/seat life in abrasive flow, greater durability for repeated on/off cycles and excellent corrosion resistance
- PTFE Glass packing provides dependable stem and body sealing with temperatures from -100° to 650°F (-70° to 340°C)
- Stem and packing gland design have been selected to achieve extended thread cycle life and reduced handle torque

Traceability of the materials used is ensured by use of heat and purchase order codes etched on valve body that also includes model number, MAWP rating, and material type references. All MVBB valves include connection collar and gland nut unless requested otherwise. Parker Autoclave Engineers' valves are complemented by a complete line of Medium Pressure Cone & Thread fittings, tubing, check valves, relief valves, and line filters that provide a reliable bubble tight seal for dependable performance in gas or liquid service.

Tube Outside Diameter Size (inches)	Connection Type	Orifice Size Inches (mm)	Rated C_v^*	Pressure Rating psi (bar) @Room Temperature**
1/4	SF250CX (1/4" MP)	0.094 (2.4)	0.20	20,000 (1380)
3/8	SF375CX (3/8" MP)	0.094 (2.4)	0.20	20,000 (1380)
1/2	NPT	0.094 (2.4)	0.20	15,000 (1035)

Notes

** For complete temperature ratings see pressure/temperature rating guide in Technical Information section.

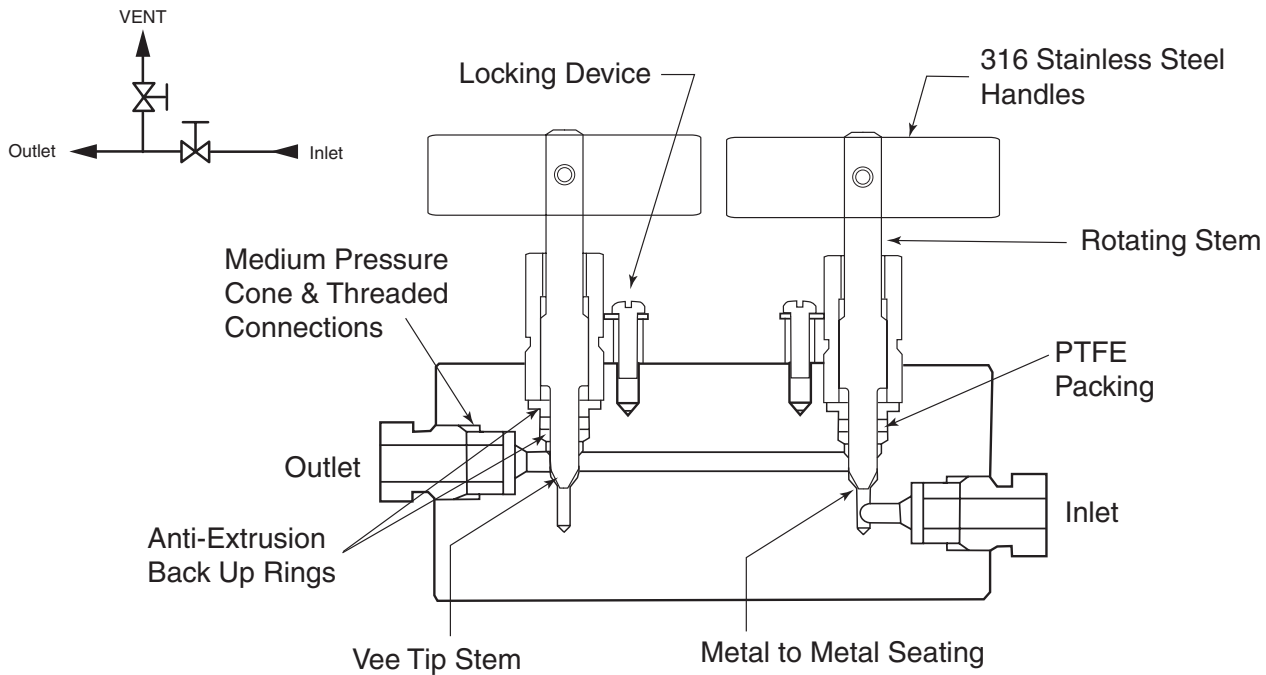

To ensure proper fit use Parker Autoclave tubing

Valve Packing Options:

Standard Parker Autoclave Engineers valves with PTFE packing may be operated to 450°F (232°C). For additional temperatures, see options below and include suffix code in part number of valve selected:

- TG** Standard valve with PTFE-Glass packing -100° to 650°F (-70 to 340°C)
- B** Cryogenic trim materials and PTFE packing required when below 0°F to -100°F (-73°C)

Note: Refer to the Tools, Installation, Operation and Maintenance catalog for proper connection, packing, seating & running torques.

Ordering Guide:

MVBB Series valves are furnished complete with connection components, unless otherwise specified. Valve options on page 15 do not apply for MVBB Manifold Valves.

Building a Part Number: Example: 20MVBB6

Example Part Number:	20MVBB	6	XX
Ordering Parameters/Options:	Valve Series	Outside Diameter Tube Size	Options
Table Reference: (see below)	A	B	C

A - Valve Series

20MVBB	20,000 psi Mini MVBB Block & Bleed Valve
15MVBB	15,000 psi Mini MVBB Block & Bleed Valves

B - Tubing OD or Pipe Size

#	1/4" MP (20MVBB option only)
6	3/8" MP (20MVBB option only)
P8	1/2" Pipe NPT only (only applicable for 15MVBB Valve Series)

E - Options (Multiple Options can be chosen)

TG	PTFE Glass (25%) Packing (to 650°F)
B	Low Temperature service required below 0°F (-18°C)
K	Antivibration Gland (replaces standard gland)
*SOG	NACE Material, Hardness Verification/Certificate
**2507	UNS 32750, 2507 Super Duplex Wetted Materials
***IN625	UNS N06625 Inconel 625 Wetted Materials

Notes:

For 1/4" MP (typically 4 code) option leave part code blank. ie; 20MVBB
316 SS valve bodies are cold worked and not suitable for use in NACE (ISO 15156) applications. If required, contact factory for options.

* SOG suffix also changes CW 316 SS Body material to Annealed 316 SS suitable for NACE service, Pressure reduction of 60% possible

*** Special Materials often have reduced MAWP ratings, see Technical brochure for assistance and for additional material options

Basic MVBB Repair Kits:

MVBB Valves are easily repaired. Add "**R**" to front of valve catalog number for proper repair kit (example: R20MVBB)

Include any catalog number suffix marked on original part when ordering repair kit. (ie; R20MVBB6-SOG)

Material of Construction:

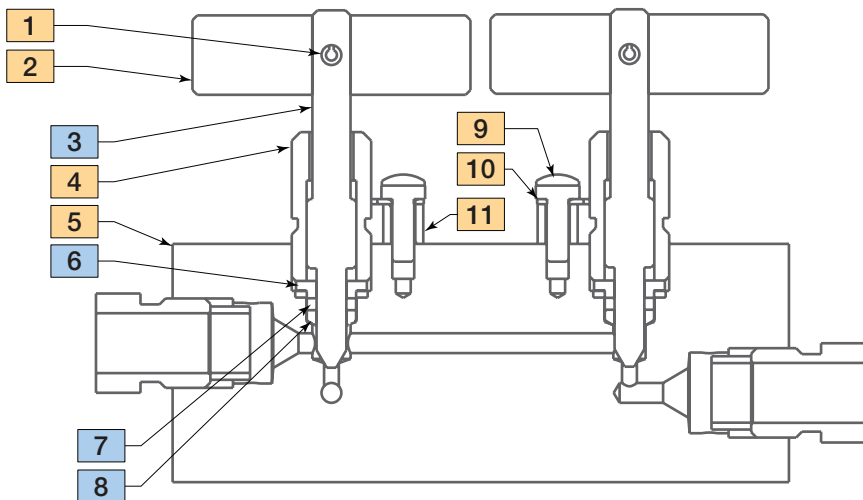

Item #	Description	Material
1	Spring Pin	18-8 SS
2	Handle	316 SS
3	Stem	316 SS
4	Packing Gland	316 SS
5	Body	316 SS
6	Packing Washer	316 SS
7	Packing	PTFE
8	Bottom Washer	316 SS
9	Screw	300 Series SS
10	Locking Device	316 SS
11	Spacer	316 SS

Typical spare parts found in Repair Kits

MVBB Series Block & Bleed Dimensions:

Block and Bleed - MVBB					
Outside Diameter Tube		1/4 (6.35)	3/8 (9.53)	1/2 NPT	
Orifice Diameter		0.094 (2.39)	0.094 (2.39)	0.094 (2.39)	
Dimensions: inches (mm)		A	B	C	
		3.50 (88.90)	3.88 (98.60)	4.5 (114.3)	
		B	0.813 (20.65)	1.00 (25.40)	1.31 (33.3)
		C	0.38 (9.65)	0.44 (11.10)	--
		D	0.625 (15.88)	0.625 (15.88)	0.75 (19)
		D1	0.938 (23.83)	0.938 (23.83)	1.25 (31.8)
		E	1.50 (38.10)	1.50 (38.10)	2.00 (50.8)
		F	1.75 (44.45)	1.75 (44.45)	1.75 (44.45)
		G	5/8" Hex	5/8" Hex	5/8" Hex
		G1	0.281 (7.14)	0.281 (7.14)	0.281 (7.14)
		H*	2.94 (74.68)	2.94 (74.68)	3.41 (86.6)
		M	2.50 (63.50)	2.88 (73.15)	3.50 (89)
		N	0.485 (12.32)	0.50 (12.70)	0.50 (12.70)
		O	1.63 (41.40)	1.63 (41.40)	1.75 (44.5)
		P	0.50 (12.7)	0.50 (12.7)	0.50 (12.7)
		Q	2.63 (66.7)	2.63 (66.7)	2.75 (70)

G1 - Bracket mounting hole size • H* - Dimension is with stem in closed position
 All dimensions for reference only and subject to change • For prompt service, Parker Autoclave stocks select products. Consult factory.

20DBNV Series: Pressures to 20,000 psi (1379 bar)

Double Block & Bleed Needle Type Manifold Valve

Principle of Operation:

Parker Autoclave Engineers DBNV double block and bleed needle valve provides true double valve isolation with a third vent valve in between for venting or bleeding, meeting both the API and OSHA valve definitions. Typically used as an interface with other components, usually pressure measurement transmitters, gauges and switches but can also be used for chemical injection, reducing leak points typical of a multi-valve fabrication.

A Double Block & Bleed valve can provide isolation in both the upstream and downstream directions, even in high-pressure or high-temperature situations. Isolation is important in cases where leakage through a valve could have major consequences.



DBNV Double Block & Bleed Manifold Valve Features:

- 20DBNV Series valve design provides large valve performance in a small package
- Tubing sizes: 1/4" to 3/4" Medium Pressure
- Rising stem/barstock body design typical of SM Series Valves
- Metal-to-metal seating achieves bubble-tight shut-off, longer stem/seat life in abrasive flow, greater durability for repeated on/off cycles and excellent corrosion resistance
- PTFE packing below stem threads provide dependable stem and body sealing. Optional packing materials available.
- Non-Rotating Stems prevent stem/seat galling
- Temperature Rated -423° to 1200°F (-252° to 650°C) with options
- Manufactured with UNS S31600/S31603 cold worked 316/316L stainless steel made to PAE proprietary standard

Parker Autoclave Engineers DBNV Manifold valves are complemented by a complete line of high pressure fittings and tubing. Traceability is ensured by use of heat and purchase order codes etched on valve body that also include model number, MAWP rating, and material type references. All valves include connection collar and gland nut unless requested otherwise.

Tube Outside Diameter Size (inches)	Connection Type	Orifice Size Inches (mm)	Rated C_v^*	Pressure Rating psi (bar) @Room Temperature**
1/4	SF250CX (1/4" MP)	0.093 (2.36)	0.10	20,000 (1379)
3/8	SF375CX (3/8" MP)	0.093 (2.36)	0.27	20,000 (1379)
9/16	SF562CX (9/16" MP)	0.312 (7.92)	0.65	20,000 (1379)
3/4	SF750CX20 (3/4" MP)	0.438 (11.2)	2.52	20,000 (1379)
1/4	F250C (1/4" HP)	0.093 (2.36)	0.08	20,000 (1379)
9/16	F562C (9/16" HP)	0.093 (2.36)	0.27	20,000 (1379)

Notes

** For complete temperature ratings see pressure/temperature rating guide in Technical Information section.

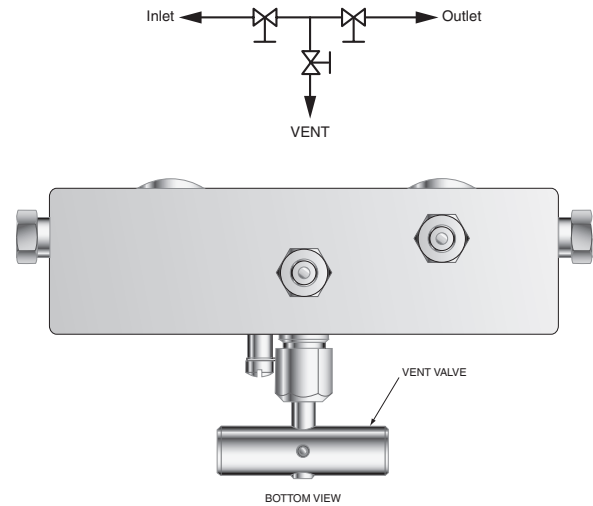
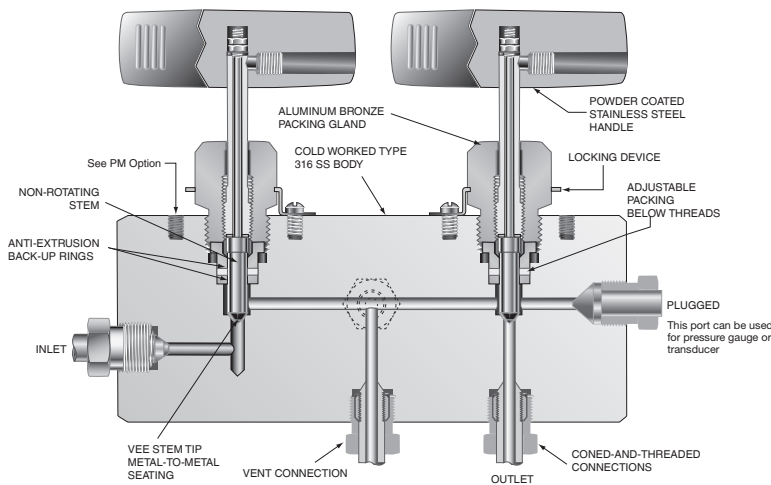

To ensure proper fit use Parker Autoclave tubing

Valve Packing Options:

Standard Parker Autoclave Engineers valves with PTFE packing may be operated from 0°F (-17.8°C) to 450°F (232°C). High and Cryogenic temperature packing and/or extended stuffing box are available for service from -423°F (-252°C) to 1200°F (650°C) by adding the following suffixes to catalog order number:

- B** Cryogenic trim materials and PTFE packing required when below 0°F (-18°C) to -100°F (-73°C)
- LT** Extended stuffing box valve with PTFE packing and Cryogenic trim materials to -423°F (-252°C)
- TG** Standard valve with PTFE-Glass packing -100°F (-73°C) to 600°F (316°C) (See also -B option above when below 0°F (-18°C))
- GY** Standard valve with Graphite Yarn packing 32°F (0°C) to 800°F (427°C). Used when selecting HT option.
Note: 3/4" valve using graphite yarn packing has significant increase in torque needed to actuate valve at pressure. Contact factory with application detail for assistance.
- HT** Extended stuffing box valve with Graphite Yarn packing to 1200°F (650°C)

(See "Technical Brochure" for Pressure/Temperature effect on temperatures above ambient.)

Ordering Guide:

For complete information on available end connections, see end connections options below. 20DBNV valves are furnished complete with tube connections.

Building a Part Number: *Example: 20DBNVM4M4-XX*

Example Part Number:	20DBNV	M4	M4	-	XX
Ordering Parameters/Options:	Valve Series	Tube Connection	Vent Connection		Options
Table Reference: (see below)	A	B	C		D

A - Valve Series

20DBNV	20,000 psi Double Block and Bleed Series Needle Valve
--------	---

B - Tube Connection (see chart below)

M4	SF250CX (1/4" MP)
M6	SF375CX (3/8" MP)
M9	SF562CX20 (9/16" MP)
M12	SF750CX (3/4" MP)
H9	F562C (9/16" HP) (API Type III connection)

C - Vent Connection

M4	SF250CX (1/4" MP) - 20,000 psi MAWP
M6	SF375CX (3/8" MP)
P4	1/4" Female NPT - 15,000 psi MAWP

D - Options (See additional options on page 15)

K	Antivibration Gland (replaces standard gland)
B	Cryogenic Trim materials required when below 0°F (-18°C) (included in LT)
LT	Low Temperature Extension (to -423°F) (includes PTFE packing)
TG	PTFE Glass (25%) Packing (to 600°F)
GY	Graphite Yarn Packing (to 800°F) [GY Packing increases Handle Torque, contact factory]
HT	High Temperature Extension (to 1200°F) (includes GY packing)
*SOG	NACE Material, Hardness Verification/Certificate
**2507	UNS 32750, 2507 Super Duplex Wetted Materials
***IN625	UNS N06625 Inconel 625 Wetted Materials

Notes:

316 SS valve bodies are cold worked and not suitable for use in NACE (ISO 15156) applications. If required, contact factory for options.

* SOG suffix also changes CW 316 SS Body material to Annealed 316 SS suitable for NACE service, Pressure reduction of 60% possible

*** Special Materials often have reduced MAWP ratings, see Technical brochure for assistance and for additional material options

Basic DBNV Repair Kits:

DBNV Valves are easily repaired. Add "R" to front of valve catalog number for proper repair kit (example: R20DBN-VH9M4).

Include any catalog number suffix marked on original part when ordering repair kit. (ie; R20DBNVH9M4-SOG).

Material of Construction:

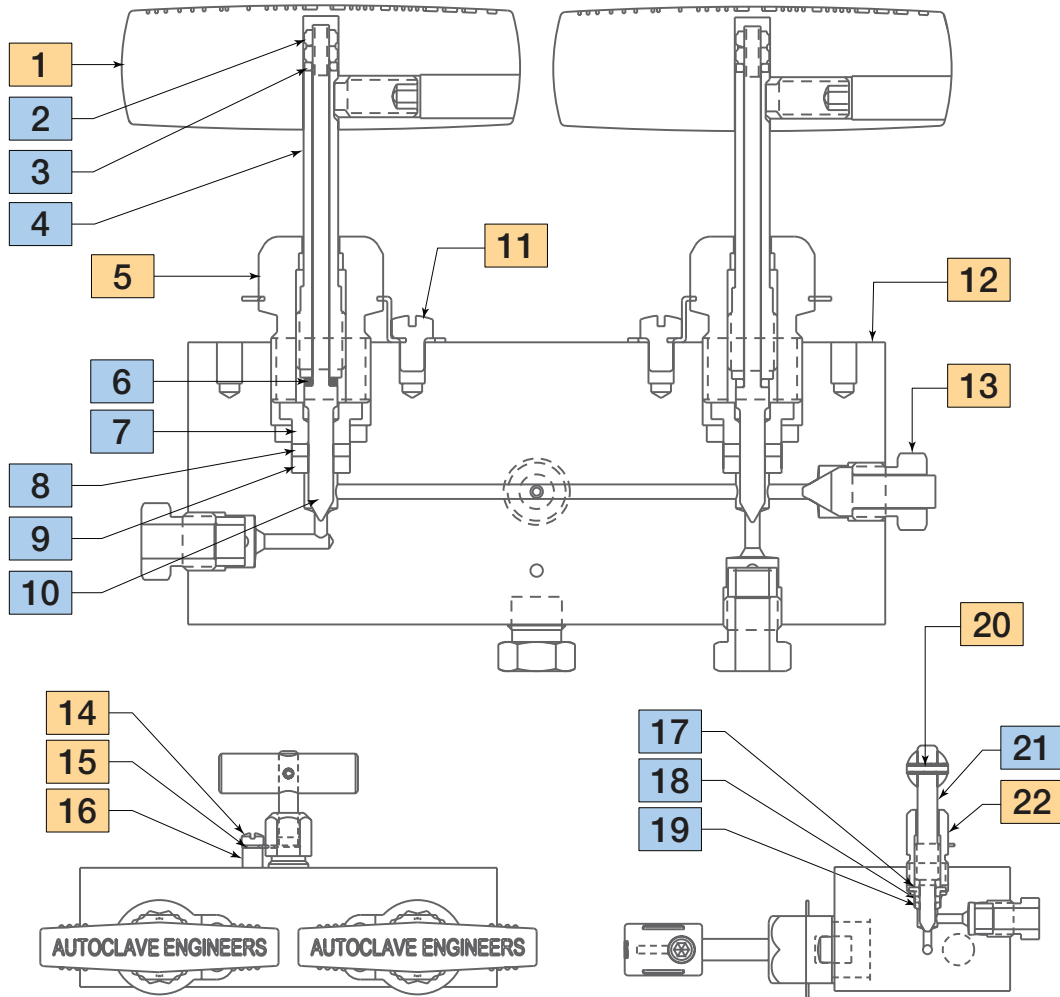

Item #	Description	Material
1	Handle	316 SS
2	Hex Nut, #5-40	300 Series SS
3	Thrust Washer	17-4 PH
4	Stem Sleeve	304 SS
5	Packing Gland	316 SS
6	Thrust Washer	17-4 PH
7	Packing Washer	AMPCO 45
8	Packing	PTFE
9	Bottom Washer	316 SS
10	Vee Stem	316 SS
11	Screw, #10	18-8 SS
12	Body	316 SS
13	Plug	316 SS
14	Screw, 3.55mm	300 Series SS
15	Locking Device	316 SS
16	Spacer	316 SS
17	Packing Washer	316 SS
18	Packing	PTFE
19	Bottom Washer	316 SS
20	Spring Pin	18-8 SS
21	Stem	316 SS
22	Packing Gland	316 SS
Typical spare parts found in Repair Kits (• indicates part not shown)		

Double Block and Bleed 20DBNV Series Dimensions:

Double Block and Bleed - 20DBNV																						
		Catalog Number																				
Stem Type	VEE	20DBNV4XX	20DBNV6XX	20DBNV9XX	20DBNVH9XX	20DBNV12XX																
Tube Connection Size		1/4-MP	3/8-MP	9/16-MP	9/16-HP	3/4 - MP																
Orifice Diameter		0.094 (2.39)	0.125 (3.2)	0.312 (7.92)	0.125 (3.2)	0.438 (11.2)																
Dimensions: inches (mm)		A	B	B1	C	D	D1	E	F	G	H*	M	N	O	P	Q	V	X	Y	Z		
		5.25 (133.35)	1.00 (25.40)	1.00 (25.40)	0.38 (9.65)	1.50 (38.10)	1.13 (28.70)	2.13 (54.10)	3.00 (76.20)	1.00 (25.40)	4.65 (118.11)	0.69 (17.53)	0.50 (12.70)	2.65 (67.31)	0.63 (16.00)	1.50 (38.10)	1.43 (36.32)	0.50 (12.70)	0.50 (12.70)	0.31 (7.87)		
		14.00 (355)	1.75 (44.50)	1.75 (44.50)	0.62 (15.75)	3.00 (76.20)	2.25 (57.20)	4.13 (105.0)	10.25 (260.0)	1.00 (25.40)	7.35 (187.0)	1.25 (31.80)	0.44 (11.2)	7.00 (177.8)	.63 (16.00)	1.75 (44.45)	1.43 (36.32)	0.50 (12.70)	0.75 (19.05)	0.81 (20.6)		
		Bracket Mounting Hole Diameter		.28 (7.11)	.28 (7.11)	.40 (10.16)	.40 (10.16)	.44 (11.2)														

G - Packing Gland mounting hole drill size • H* - Dimension is with stem in closed position • * 3/4" Mounting Holes are parallel (at top of valve) using dimensions given.
 Panel mounting drill size: 0.22" all valves • All dimensions for reference only and subject to change • For prompt service, Parker Autoclave stocks select products. Consult factory.

For complete information on available options, contact your Sales representative. 20DBNV Series valves are furnished with connection components unless otherwise specified.

Oil & Gas Wellhead Gauge/Bleed Valve:

API 6A Single Block Gauge Valve with Optional Bleed Valve

Pressures to 30,000 psi (2070 bar)

Principle of Operation:

Parker Autoclave Engineers Wellhead Gauge valve was designed using the API Type III connection (9/16" HP) and materials suitable for use in NACE (SOG) defined corrosive applications. The 9/16" HP connection - designed for non-NACE 30,000 psi application, when used with Annealed 316 SS instead of our standard cold worked 316 SS, is suitable to 20,000 psi MAWP. Standard Material Medium Pressure connections hold MAWP to 20,000 psi.

The 30GV is a single block valve with one inlet and 3 shared outlet connections. A separate Bleed Valve (20BV or 30BV) optioned with the same 9/16" HP Male connection as explained above, can be used in any of these ports to provide the bleed function if required. The other ports can be used with Pressure Gauge (PAE H-Style) and/or Pressure or Temperature Transmitter.

Bleed/Vent Valve can also be used to evacuate trapped air from pressure systems up to 30,000 psi (2070 bar)

Wellhead Gauge Features:

- One inlet, three outlet of same size and type
- Metal-to-metal bubble tight shut-off
- PTFE packing below stem threads provides dependable sealing
- UNS S31600/S31603 cold worked 316 SS as standard (optional annealed materials available)

Bleed Valve Features:

- One piece hex body construction allows easy installation
- Vent port tapped 1/8" NPT for plumbing to safe area
- Tee handle for easy operation
- Positive blow out prevention on stem
- "Adapter Male" * One Piece Male Medium or High Pressure connection, sized as required
- *Adapter Male connection is made to include the matching gland thread as well as the collar spacing and the typical tubing cone tip to form a one-piece connection.

Warning: Vent Outlet position is not controllable once torqued or damage will occur.



GV Series Wellhead Gauge



BV Series Bleed/Vent Valve

Series	Tube Outside Diameter Size (inches)	Connection Type	Orifice Size Inches (mm)	Rated C _v *	Cold Worked 316 SS Pressure Rating psi (bar)	Annealed (NACE) 316 SS Pressure Rating psi (bar)
Wellhead Gauge Valve						
20GV	3/8	SF375CX (3/8" MP)	0.125 (3.18)	0.23	20,000 (1380)	10,000 (690)
20GV	9/16	SF562CX (9/16" MP)	0.125 (3.18)	0.23	20,000 (1380)	10,000 (690)
30GV	9/16	F562C (9/16" HP)	0.125 (3.18)	0.33	30,000 (2070)	20,000 (1380)

Bleed Valve						
20BV	3/8	@ ASM375CX (3/8" MP)	0.093 (2.36)	-	20,000 (1380)	10,000 (690)
20BV	9/16	@ ASM562CX (9/16" MP)	0.093 (2.36)	-	20,000 (1380)	10,000 (690)
30BV	3/8	@ AM375C (3/8" HP)	0.093 (2.36)	-	30,000 (2070)*	20,000 (1380*)
30BV	9/16	@ AM562C (9/16" HP)	0.093 (2.36)	-	30,000 (2070)*	20,000 (1380*)

Notes

* Rating shown is in closed position.

@ For Explanation of ASM Connection, see Adapter Section in Catalog

BV Valve Rating @ 15,000 psi (1035 bar) in open position.

Glands and collars included in all standard assemblies. Consider using "-WO" suffix when using BV Bleed Valve and/or H-Style Gauge that won't require use.

Ordering Guide:

Catalog number is created based on customer selection of product parameters, see below for example.

GV Series Wellhead Gauge Valve

Building a Part Number: <i>Example: 30GV9078-XXX</i>						
Example Part Number:	30GV	9	07	8	-	XXX
Ordering Parameters/Options:	Valve Series	Outside Diameter Tube Size	Stem Type	Body Pattern		Options
Table Reference: (see below)	A	B	C	D		E

A - Valve Series	
20GV	Wellhead Gauge Valve
30GV	Wellhead Gauge Valve

B - Outside Diameter Tube Size	
6	3/8"
9	9/16"

C - Stem Type	
00	One Piece Vee Stem
07	Non-Rotating Vee Stem

D - Body Pattern	
8	4 Ports, 1 Inlet, 3 Outlets

E - Options	
WO	"With Out" Collar and Gland in all connectons
K	Antivibration Gland (replaces standard gland)
B	Cryogenic Trim materials required when below 0°F (-18°C) (included in LT)
TG	PTFE Glass (25%) Packing (to 600°F)
*SOG	NACE Material, Hardness Verification/Certificate
***HC	UNS N10276 Hastelloy C276, Wetted Materials (Annealed)
***IN625	UNS N06625 Inconel 625 Wetted Materials (Annealed)
***2507	UNS 32750, 2507 Super Duplex Wetted Materials (Annealed)

Notes:

316 SS valve bodies are cold worked and not suitable for use in NACE (ISO 15156) applications. If required, contact factory for options.

* SOG suffix also changes CW 316 SS Body material to Annealed 316 SS suitable for NACE service, Pressure reduction of 60% possible

*** Special Materials often have reduced MAWP ratings, see Technical brochure for assistance and for additional material options

GV Series Wellhead Gauge Valve Dimensions:

Wellhead Gauge Valve						
		Catalog Number				
Stem Type	Vee Type (only)	20GV6078	20GV9078	30GV9078		
Tube Connection Type		SF375CX (3/8" MP)	SF562CX (9/16" MP)	F562C (9/16" HP)		
Tube Connection Size		3/8 MP	9/16 MP	9/16 HP		
Pressure Rating: psi (bar)		20,000 (1380)	20,000 (1380)	30,000 (2070)		
Dimensions: inches (mm)		A	B	C		
		2.00 (50.80)	2.00 (50.80)	2.00 (50.80)		
		3.12 (79.25)	3.88 (98.55)	3.88 (98.55)		
		2.00 (50.80)	2.75 (69.85)	2.75 (69.85)		
		4.5 (115)	4.5 (115)	4.5 (115)		
		1.13 (28.58)	1.31 (33.27)	1.31 (33.27)		
		1.00 (25.40)	1.38 (34.93)	1.38 (34.93)		
		0.50 (12.70)	0.66 (16.76)	0.66 (16.76)		
		0.94 (23.83)	0.94 (23.83)	0.94 (23.83)		
		3.00 (76.20)	3.00 (76.20)	3.00 (76.20)		
		.25 (6)	.38 (10)	.38 (10)		
		.25 (6)	.38 (10)	.38 (10)		
		Mounting Hole Dimensions		M		
				.28 (7)	.28 (7)	.28 (7)

All dimensions for reference only and subject to change • For prompt service, Parker Autoclave stocks select products. Consult factory.

Material of Construction:

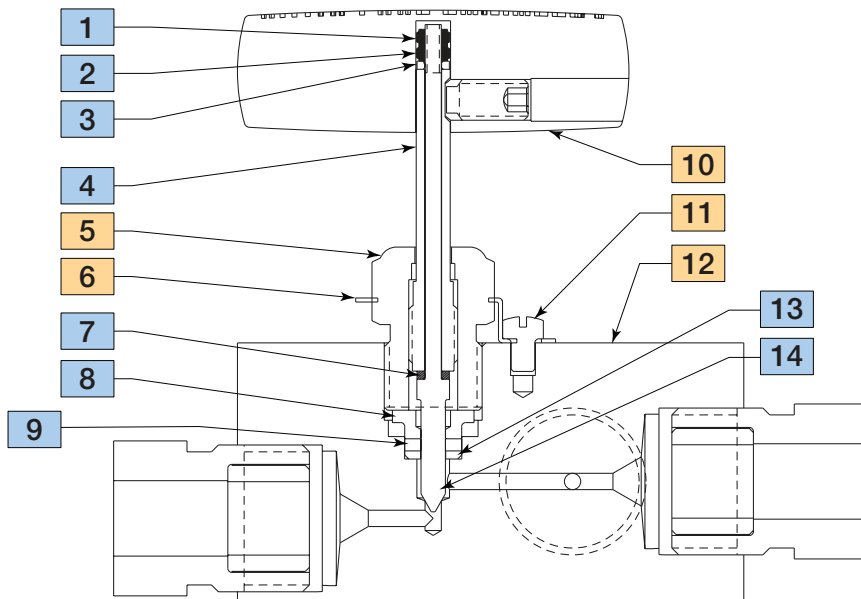

Item #	Description	Material
1	Hex Nut	300 Series SS
2	Hex Nut	300 Series SS
3	Stem	316 SS
4	Sleeve	304 SS
5	Packing Gland	AMPCO 45
6	Locking Device	302 SS
7	Thrust Washer	17-4PH
8	Packing Washer	AMPCO 45
9	Packing	PTFE
10	Handle	316 SS
11	Screw	300 Series SS
12	Body	316 SS
13	Bottom Washer	316 SS
14	Vee Stem	316 SS

Typical spare parts found in Repair Kits

Ordering Guide:

Catalog number is created based on customer selection of product parameters, see below for example.

BV Series Bleed/Vent Valve (order individually)

Building a Part Number: <i>Example: 30BV9002-XXX</i>					
Example Part Number:	30BV	9	00	2	XXX
Ordering Parameters/Options:	Valve Series	Outside Diameter Tube Size	Stem Type	Body Pattern	Options
Table Reference: (see below)	A	B	C	D	E

A - Valve Series	
20BV	20,000 psi Medium Pressure Bleed Valve
30BV	30,000 psi High Pressure Bleed Valve

B - Outside Diameter Tube Size	
4	1/4" Adapter Male (AM)
6	3/8" Adapter Male (AM375CX)
9	9/16" Adapter Male (AM562CX MP or AM562C HP)

C - Stem Type	
00	One Piece Vee Stem

D - Body Pattern	
2	Angle (bottom inlet)

E - Options	
*SOG	NACE Material, Hardness Verification/Certificate
***HC	UNS N10276 Hastelloy C276, Wetted Materials (Annealed)
***IN625	UNS N06625 Inconel 625 Wetted Materials (Annealed)
***2507	UNS 32750, 2507 Super Duplex Wetted Materials (Annealed)

Notes:
316 SS valve bodies are cold worked and not suitable for use in NACE (ISO 15156) applications. If required, contact factory for options.

* SOG suffix also changes CW 316 SS Body material to Annealed 316 SS suitable for NACE service, Pressure reduction of 60% possible

*** Special Materials often have reduced MAWP ratings, see Technical brochure for assistance and for additional material options

Bleed Valve Dimensions:

Bleed/Vent Valve					
		Catalog Number			
Stem Type	VEE	20BV4002	20BV6002	20BV9002	30BV9002
Connection Type		SM250CX	SM375CX	SM562CX	M562C
Connection Size		1/4 MP	3/8 MP	9/16 MP	9/16 HP
Pressure Rating: psi (bar)		20,000 (1380)	20,000 (1380)	20,000 (1380)	30,000 (2070)
Dimensions: inches (mm)		A	B	C	D
		3.06 (78)	3.23 (82.04)	3.68 (93.47)	3.44 (87.38)
		2.25 (57)	2.42 (61.47)	2.86 (76.64)	2.61 (66.29)
		1.12 (28.5)	1.12 (28.45)	1.12 (28.45)	1.12 (28.45)
		1.38 (35)	1.38 (35.05)	1.38 (35.05)	1.38 (35.05)
		1.50 (38)	1.50 (38.10)	1.50 (38.10)	1.50 (38.10)

Notes:
*Adapter Male connection is made to include the matching gland thread and collar spacing along with typical tubing tip to form one-piece connection. "Warning" Rotation position is not controllable once torqued or damage will occur.
Bleed Valve max pressure is reduced to 15,000 psi when in OPEN position due to outlet connection

All dimensions for reference only and subject to change • For prompt service, Parker Autoclave stocks select products. Consult factory.

Material of Construction:

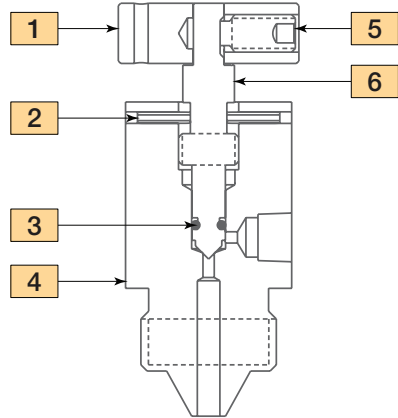

Item #	Description	Material
1	Handle	Aluminum
2	Spring Pin	18-8 SS
3	O-Ring	FKM
4	Body	316 SS
5	Hex Socket Set Screw	300 Series SS
6	Stem	316 SS

Note: No Repair Kit available for this item

Valve Options:

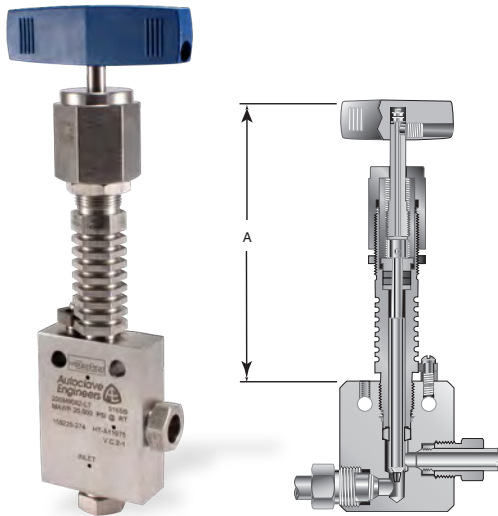

High/Low Temperature Extension:

This option is only available on 20DBNV Double Block & Bleed Valves.

- HT High Temperature (over 800°F (427°C))
- LT Low Temperature (under -100°F (-73°C))

Valve Series	Outside Diameter Tube Size (inches)	Dimensions "A" inches (mm)	Vent Stem Extension (Not Shown)
20DBNV	1/4"	6.16 (157)	5.68 (144)
	3/8"	6.16 (157)	5.68 (144)
	9/16"	6.62 (160)	5.68 (144)

HT option code includes Graphite (-GY) packing
LT option code includes 316 SS Trim material and PTFE packing



Needle Valve Clam Shell Handle Lockout:

(order separately using part numbers shown below, padlock not included)

Clam Shell Handle locks are provided to lockout valves in open or closed position preventing unauthorized personnel from actuating valve during shutdown or emergency situations. This clamshell design is available in four (4) sizes dependent on handle length:

- P/N AE004855 – 1" to 2.5" handle length
- P/N 90088 – 2.5" to 5.0" handle length
- P/N 90194 – 6.5" to 10" handle length
- P/N AE004350 – 8" to 13" handle length

Parker Worldwide

North America

USA – Corporate, Cleveland, OH
Tel: +1 256 896 3000

USA – IPD, Huntsville, AL
Tel: +1 256 881 2040
ipdctt@parker.com

USA – IPD, (Autoclave), Erie, PA
Tel: +1 814 860 5700
ipdaectt@parker.com

CA – Canada, Grimsby, Ontario
Tel: +1 905-945-2274
ipd_canada@parker.com

South America

AR – Argentina, Buenos Aires
Tel: +54 3327 44 4129
falecom@parker.com

BR – Brazil, Diadema, SP
Diadema, SP
Tel: +55 11 4360 6700
falecom@parker.com

CL – Chile, Santiago
Tel: +56 (0) 2 2303 9640
falecom@parker.com

MX – Mexico, Toluca
Tel: +52 722 275 4200
contacto@parker.com

Asia Pacific

AU – Australia, Dandenong
Tel: +61 (0)2 9842 5150
customer.service.au@parker.com

CN – China, Shanghai
Tel: +86 21 2899 5000
INGtechnical.china@parker.com

HK – Hong Kong
Tel: +852 2428 8008

IN – India, Mumbai
Tel: +91 22 6513 7081-85

ID – Indonesia, Tangerang
Tel: +62 2977 7900
parker.id@parker.com

JP – Japan, Tokyo
Tel: +(81) 3 6365 4020
infophj@parker.com

KR – South Korea, Seoul
Tel: +82 2 559 0400
parkerkr@parker.com

MY – Malaysia, Selangor
Tel: +603 784 90 800
parkermy@parker.com

SG – Singapore,
Tel: +65 6887 6300
parkerkg@parker.com

TH – Thailand, Bangkok
Tel: +66 2 186 7000
phthailand@parker.com

TW – Taiwan, Taipei
Tel: +886 2 2298 8987
enquiry.taiwan@parker.com

VN – Vietnam, Hanoi
Tel: +848 382 508 56
parker_viet@parker.com

Europe, Middle East, Africa

AE – UAE, Dubai
Tel: +971 4 812 7100
parker.me@parker.com

AT – Austria, Wiener Neustadt
Tel: +43 (0)2622 23501-0
parker.austria@parker.com

AT – Eastern Europe, Wiener Neustadt
Tel: +43 (0)2622 23501 900
parker.easturope@parker.com

AZ – Azerbaijan, Baku
Tel: +994 50 2233 458
parker.azerbaijan@parker.com

BE/LU – Belgium, Nivelles
Tel: +32 (0)67 280 900
parker.belgium@parker.com

BG – Bulgaria, Sofia
Tel: +359 2 980 1344
parker.bulgaria@parker.com

BY – Belarus, Minsk
Tel: +48 (0)22 573 24 00
parker.belarus@parker.com

CH – Switzerland, Etoy
Tel: +41 (0) 21 821 87 00
parker.switzerland@parker.com

CZ – Czech Republic, Klecany
Tel: +420 284 083 111
parker.czechrepublic@parker.com

DE – Germany, Kaarst
Tel: +49 (0)2131 4016 0
parker.germany@parker.com

DK – Denmark, Ballerup
Tel: +45 43 56 04 00
parker.denmark@parker.com

ES – Spain, Madrid
Tel: +34 902 33 00 01
parker.spain@parker.com

FI – Finland, Vantaa
Tel: +358 (0)20 753 2500
parker.finland@parker.com

FR – France, Contamine s/Arve
Tel: +33 (0)4 50 25 80 25
parker.france@parker.com

GR – Greece, Athens
Tel: +30 210 933 6450
parker.greece@parker.com

HU – Hungary, Budapest
Tel: +36 223 885 470
parker.hungary@parker.com

IE – Ireland, Dublin
Tel: +353 (0)1 466 6370
parker.ireland@parker.com

IT – Italy, Corsico (MI)
Tel: +39 02 45 19 21
parker.italy@parker.com

KZ – Kazakhstan, Almaty
Tel: +7 7273 561 000
parker.easturope@parker.com

NL – The Netherlands, Oldenzaal
Tel: +31 (0)541 585 000
parker.nl@parker.com

NO – Norway, Stavanger
Tel: +47 66 75 34 00
parker.norway@parker.com

PL – Poland, Warsaw
Tel: +48 (0)22 573 24 00
parker.poland@parker.com

PT – Portugal, Leca da Palmeira
Tel: +351 22 999 7360
parker.portugal@parker.com

RO – Romania, Bucharest
Tel: +40 21 252 1382
parker.romania@parker.com

RU – Russia, Moscow
Tel: +7 495 645-2156
parker.russia@parker.com

SE – Sweden, Spånga
Tel: +46 (0)8 59 79 50 00
parker.sweden@parker.com

SK – Slovakia, Banská Bystrica
Tel: +421 484 162 252
parker.slovakia@parker.com

SL – Slovenia, Novo Mesto
Tel: +386 7 337 6650
parker.slovenia@parker.com

TR – Turkey, Istanbul
Tel: +90 216 4997081
parker.turkey@parker.com

UA – Ukraine, Kiev
Tel: +48 (0)22 573 24 00
parker.ukraine@parker.com

UK – United Kingdom, Warwick
Tel: +44 (0)1926 317 878
parker.uk@parker.com

ZA – South Africa, Kempton Park
Tel: +27 (0)11 961 0700
parker.southafrica@parker.com

! CAUTION !

Do not mix or interchange component parts or tubing with those of other manufacturers. Doing so is unsafe and will void warranty.

Parker Autoclave Engineers Valves, Fittings, and Tools are not designed to interface with common commercial instrument tubing and are designed to only connect with tubing manufactured to Parker Autoclave Engineers AES specifications. Failure to do so is unsafe and will void warranty.

WARNING

FAILURE, IMPROPER SELECTION OR IMPROPER USE OF THE PRODUCTS AND/OR SYSTEMS DESCRIBED HEREIN OR RELATED ITEMS CAN CAUSE DEATH, PERSONAL INJURY AND PROPERTY DAMAGE.

This document and other information from Parker Hannifin Corporation, its subsidiaries and authorized distributors provide product and/or system options for further investigation by users having technical expertise. It is important that you analyze all aspects of your application and review the information concerning the product or system in the current product catalog. Due to the variety of operating conditions and applications for these products or systems, the user, through its own analysis and testing, is solely responsible for making the final selection of the products and systems and assuring that all performance, safety and warning requirements of the application are met. The products described herein, including without limitation, product features, specifications, designs, availability and pricing, are subject to change by Parker Hannifin Corporation and its subsidiaries at any time without notice.

Offer of Sale

The items described in this document are available for sale by Parker Hannifin Corporation, its subsidiaries or its authorized distributors. Any sale contract entered by Parker will be governed by the provisions stated in Parker's standard terms and conditions of sale (copy available upon request).



Instrumentation Products Division
Autoclave Engineers Operation
8325 Hessinger Drive
Erie, PA 16509-4679
Tel: 814 860 5700
Fax: 814 860 5811
www.autoclave.com
www.parker.com/ipd

Instrumentation Products Division
Division Headquarters
1005 A Cleaner Way
Huntsville, AL 35805 USA
Tel: 256 881 2040
Fax: 256 881 5072

Parker Hannifin Manufacturing Ltd.
Instrumentation Products Division,
Europe
Riverside Road
Pottington Business Park
Barnstaple, UK, EX31 1NP, UK
Tel: 44 1271 313131
Fax: 44 1271 373636