

Needle Valve

Bottle Valve Series

Low Pressures to 15,000 psi (1034 bar)



Principle of Operation:

Since 1945 Parker Autoclave Engineers has designed and built premium quality valves, fittings and tubing. Parker Autoclave Engineers has long been established as the world leader in high-pressure fluid handling components for the chemical/petrochemical, research, and oil and gas industries. Bottle valves are used on sample bottles and cylinders for remote sampling in the oil industry.

Mini Series Valve Features:

- BTV Series valve design provides male inlet connections from 1/8" to 1/2" NPT.
- Outlet connections in NPT or tube to 1"
- Rising stem/barstock body design
- Non-rotating stem prevents stem/seat galling
- Metal-to-metal seating achieves bubble-tight shut-off, longer stem/seat life in abrasive flow, greater durability for repeated on/off cycles and excellent corrosion resistance
- PTFE encapsulated packing provides dependable stem and body sealings
- Stem sleeve and packing gland materials have been selected to achieve extended thread cycle life and reduced handle torque
- Vee stem tip provided
- Available in five body patterns
- Mini valves available with metric tube glands

Parker Autoclave Engineers valves are complemented by a complete line of low pressure fittings, tubing, check valves and line filters. The Bottle Valve Series use Parker Autoclave Engineers' SpeedBite connection. This single-ferrule compression sleeve connection delivers fast, easy make-up and reliable bubble-tight performance in liquid or gas service.

All Parker Autoclave Engineers products are designed in accordance with ASME B31.3 Chapter IX High Pressure Piping standards.



ENGINEERING YOUR SUCCESS.

Bottle Valve Series: Pressures to 15,000 psi (1034 bar)



Tube Outside Diameter Size (inches)	Connection Type	Orifice Size Inches (mm)	Rated C_v^*	Pressure Rating psi (bar) @Room Temperature**
1/16	W062	0.055 (1.40)	0.05	15,000 (1034)
1/8	W125	0.078 (1.98)	0.11	15,000 (1034)

Notes

* C_v values shown are for 2-way straight valve pattern. For 2-way angle patterns, increase C_v value 50%. (Based on water)

** For complete temperature ratings see pressure/temperature rating guide in Technical Information section.

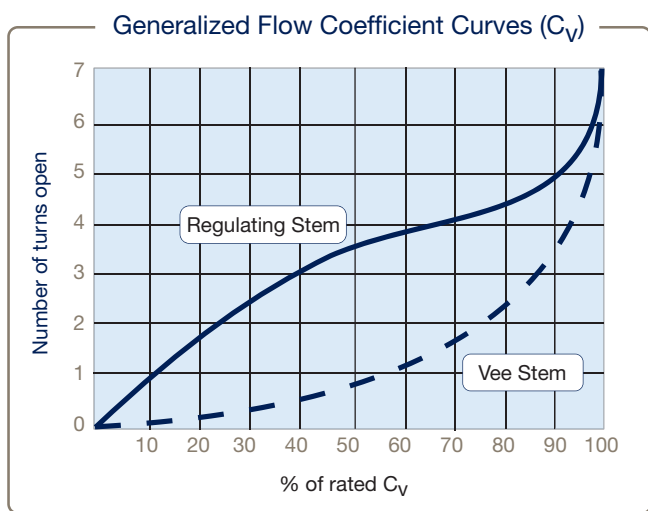

Bottle Valve Series Flow Curve

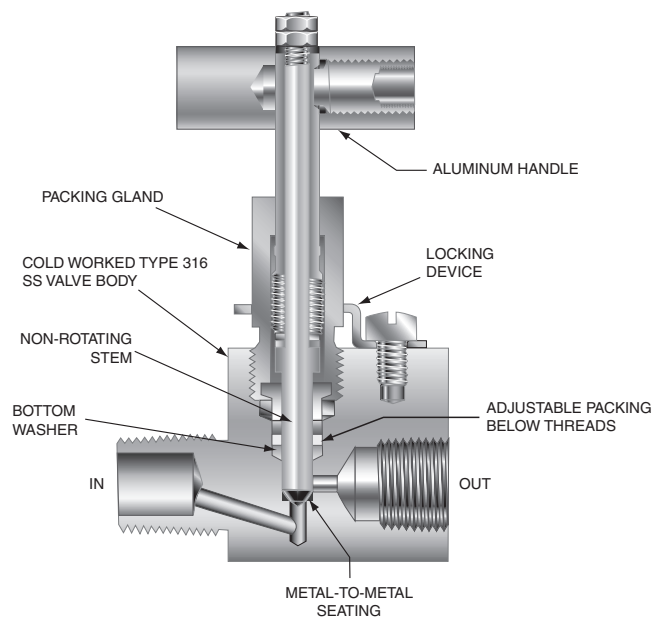

To ensure proper fit use Parker Autoclave tubing

Valve Options:

Extreme Temperatures

Standard Parker Autoclave Engineers valves with PTFE packing may be operated to 450°F (232°C). High temperature packing is available for service from 0°F (-17.8°C) to 600°F (316°C) by adding the following suffixes to catalog order number:†

TG Standard valve with PTFE glass packing to 600°F (316°C).

† Parker Autoclave Engineers does not recommend MV/MVE compression sleeve connections below 0°F (-17.8°C) or above 650°F (343°C). For additional valve options, contact your Sales Representative.

Ordering Guide:

For complete information on available stem types, optional connections and additional valve options, see Needle Valve Options section or contact your Sales Representative. BTV Series valves are furnished complete with connection components, unless otherwise specified.

Building a Part Number: Example: BTV4S4P1

Example Part Number:	BTV	4	S	4	P	1	XX
Ordering Parameters/Options:	Valve Series	Inlet Male NPT	Inlet Male NPT Position	Female Outlet Port Size	Female Outlet Connection	Body Pattern	Options
Table Reference: (see below)	A	B	C	D	E	F	G

A - Valve Series

BTV	Bottle Valve Needle Valve
-----	---------------------------

B - Inlet Male NPT

2	1/8"
4	1/4"
6	3/8"
8	1/2"

C - Inlet Male NPT Position

F	Front
S	Side
B	Bottom

D - Female Outlet Port Size

2	1/8"
4	1/4"
6	3/8"
8	1/2"

E - Female Outlet Connection

P	NPT
L6	Low Pressure

DF - Body Pattern

1	Straight
2	Angle
3	3 Way, 2 on Pressure (*2)
4	3 Way, 1 on Pressure (*1)

E - Options

For extreme temperatures and other options, see Valve Options.

R	Regulating Stem
---	-----------------

Note:

(*1) = Inlet is NPT Male

(*2) = Inlets are NPT Male and one Female Connection

Material of Construction:

Item #	Description	Material
1	Hex Nut	300 Series SS
2	Stem Sleeve	K-Monel
3	Thrust Washer	17-4 PH
4	Packing Washer	AMPCO 45
5	Bottom Washer	316 SS
6	Stem Head	MP35N
7	Thrust Washer	17-4 PH
8	Upper Stem (1" 20DV shown)	MP35N
9	Groove Pin	300 Series SS
10	Packing	PTFE
11	Lower Stem	MP35N

Typical spare parts found in Repair Kits

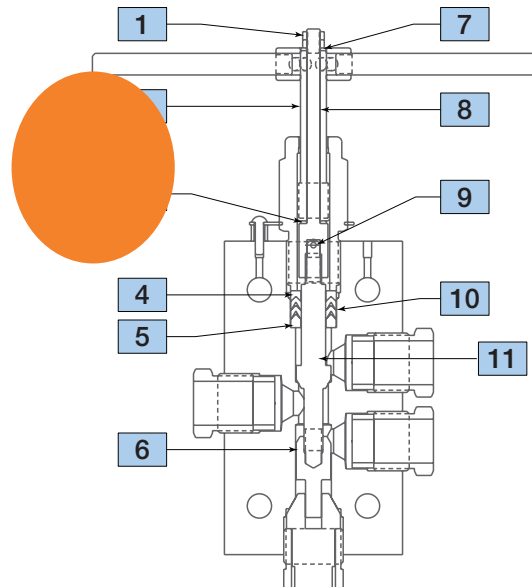

Basic Repair Kits for 316 SS Material:

Basic Repair Kit for 316 SS Material

Stem Type		1/16"		1/8"	
2 Way Straight 2 Way Angle	VEE REG	-		-	
2 Way, Replaceable Seat and Stem	VEE REG	-		-	
3 Way, 2 Stem Manifold	VEE REG	-		-	

Consult your Parker Autoclave Engineers representative for other kit numbers, body part numbers, and pricing.
Visit www.autoclave.com for product Operation manuals.

Bottle Valve Series Dimensions:

2 Way Straight - Side Inlet

Stem Type		VEE		Catalog Number					
				BTV2S2L1	BTV4S4P1	BTV8S8P1			
Outside Diameter Tube		1/8 (3.18)		1/4 (6.35)		1/2 (12.70)			
Orifice Diameter		0.094 (2.39)		0.094 (2.39)		0.203 (5.16)			
Dimensions: inches (mm)		A	1.81 (45.97)	2.00 (50.80)	3.00 (76.20)				
		B	1.31 (33.27)	1.31 (33.27)	1.00 (25.40)				
		C	0.50 (12.70)	0.69 (17.53)	0.75 (19.05)				
		D	0.82 (20.83)	0.82 (20.83)	0.82 (20.83)				
		D1	0.82 (20.83)	0.82 (20.83)	-				
		D2	-	-	-				
		E	1.28 (32.51)	1.28 (32.51)	1.38 (35.05)				
		F	1.50 (38.10)	1.50 (38.10)	1.50 (38.10)				
		G	0.56 (14.22)	0.61 (15.49)	0.68 (17.27)				
		H	3.43 (87.12)	3.41 (86.61)	3.53 (89.66)				
		M	0.56 (14.22)	0.56 (14.22)	0.56 (14.22)				
		Block Thickness			0.56 (14.27)	0.56 (14.27)	0.56 (14.27)		

G - Packing Gland mounting hole drill size • H - Dimension is with stem in closed position • All dimensions for reference only and subject to change
For prompt service, Parker Autoclave stocks select products. Consult factory.

Bottle Valve Series Dimensions:

2 Way Straight - Front Inlet			
		Catalog Number	
Stem Type	VEE	BTV4F2L1	BTV4F4L1
Outside Diameter Tube		1/8 (3.18)	1/4 (6.35)
Orifice Diameter		0.094 (2.39)	0.125 (3.18)
Dimensions: inches (mm)		A	2.00 (50.80)
		B	0.75 (19.05)
		C	0.63 (15.88)
		D	0.81 (20.57)
		D1	-
		D2	0.88 (22.35)
		E	1.38 (35.05)
		F	1.50 (38.10)
		G	0.61 (15.49)
		H	3.49 (88.65)
		M	0.56 (14.22)
		Block Thickness	

2 Way Angle - Bottom Inlet						
		Catalog Number				
Stem Type	VEE	BTV2B2P2	BTV4B2L2	BTV4B4P2	BTV8B8P2	
Outside Diameter Tube		1/8 (3.18)	1/8 (3.18)	1/4 (6.35)	1/2 (12.70)	
Orifice Diameter		0.094 (2.39)	0.094 (2.39)	0.203 (5.16)	0.203 (5.16)	
Dimensions: inches (mm)		A	2.00 (50.80)	1.50 (38.10)	2.25 (57.15)	
		B	0.50 (12.70)	1.00 (25.40)	0.88 (22.35)	
		C	0.50 (12.70)	1.00 (25.40)	0.88 (22.35)	
		D	-	1.19 (30.23)	1.19 (30.23)	1.19 (30.23)
		D1	-	-	-	-
		D2	-	-	-	-
		E	1.28 (32.51)	1.63 (41.40)	1.63 (41.40)	2.13 (54.10)
		F	1.50 (38.10)	1.50 (38.10)	3.00 (76.20)	1.50 (38.10)
		G	0.56 (14.22)	0.75 (19.05)	0.75 (19.05)	0.68 (17.27)
		H	3.93 (99.82)	4.75 (120.65)	5.30 (134.62)	5.31 (134.87)
		M	0.56 (14.22)	0.62 (15.75)	0.62 (15.75)	0.63 (16.00)
		Block Thickness		0.75 (19.05)	0.75 (19.05)	0.75 (19.05)

G - Packing Gland mounting hole drill size • H - Dimension is with stem in closed position • All dimensions for reference only and subject to change
For prompt service, Parker Autoclave stocks select products. Consult factory.

Bottle Valve Series Dimensions:

3 Way, 2 on Pressure - Front Inlet		
		Catalog Number
Stem Type	VEE	BTV4F2L3
Outside Diameter Tube		1/8 (3.18)
Orifice Diameter		0.094 (2.39)
Dimensions: inches (mm)		A 1.50 (38.10)
		B 0.75 (19.05)
		C 0.63 (15.88)
		D 0.81 (20.57)
		D1 1.06 (26.92)
		D2 0.88 (22.35)
		E 1.38 (34.93)
		F 1.50 (38.10)
		G 0.75 (19.05)
		H 3.49 (88.65)
		M 0.50 (12.70)
Block Thickness		0.75 (19.05)

3 Way, 1 on Pressure - Front Inlet		
		Catalog Number
Stem Type	VEE	BTV4F2L4 BTV4F4L4
Outside Diameter Tube		1/8 (3.18) 1/4 (6.35)
Orifice Diameter		0.094 (2.39) 0.125 (3.18)
Dimensions: inches (mm)		A 1.50 (38.10) 2.00 (50.80)
		B 0.75 (19.05) 1.00 (25.40)
		C 0.63 (15.88) 0.75 (19.05)
		D 0.81 (20.57) 0.82 (20.83)
		D1 0.81 (20.57) 0.82 (20.83)
		D2 0.88 (22.35) -
		E 1.38 (34.93) 1.38 (34.93)
		F 1.50 (38.10) 1.50 (38.10)
		G 0.75 (19.05) 0.56 (14.27)
		H 3.49 (88.65) 3.53 (89.66)
		M 0.50 (12.70) 0.56 (14.22)
Block Thickness		0.75 (19.05) 0.75 (19.05)

G - Packing Gland mounting hole drill size • H - Dimension is with stem in closed position • All dimensions for reference only and subject to change
For prompt service, Parker Autoclave stocks select products. Consult factory.

Valve Options: (For Actuator Options please reference specific Actuator brochure)



Pneumatic Valve Actuators:

The need to control process and vent valves from a remote location makes air operated valves a vital component to many processing operations. All Parker Autoclave Engineers' valves are available with piston type actuators. Five sizes of air actuators (light, mini-light, medium, heavy duty or extra heavy, single and double stage) are offered to meet the service requirements of Parker Autoclave Engineers' Low, Medium and High Pressure needle valves. Both air-to-open (normally closed) and air-to-close (normally open) designs are included in the product line. Optional air to open AND close actuators available upon request. Please see our Pneumatic Valve Actuator Brochure to help size the proper actuator for your application.



Electric Valve Actuators:

Remotely controlling process flow at high pressure enhances safety and lowers labor costs. Parker Autoclave Engineers developed a flow control valve available in several models including weatherproof and explosionproof options.

The Electrically Actuated Shut-off/Flow Regulating Actuator (FRC Series) is available for most of our Needle Valves through 9/16" tubing size and up to 60,000 psi maximum pressure. They are available in all body patterns except 3-Way / 2-Stem Manifold, and can withstand wide process temperature ranges.

Please consult the appropriate needle valve brochure for information on valve options, ratings, flow coefficient, body dimensions, and other specifications.

Stem Options:

Most Parker Autoclave Engineers' valves are available with either Vee (on-off) or Regulating (Flow Control) Stems in our standard valve body seat or with our optional replaceable seat as shown below:

VEE Stem

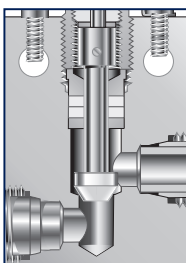

The Vee stem is used for direct on-off, metal-to-metal shut-off with quick-opening flow characteristics.

Regulating Stem

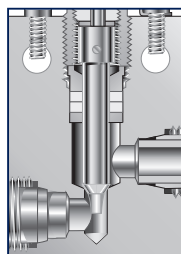

In some applications, more precise flow control is required than is possible with a Vee stem. For these cases, Autoclave offers a non-rotating, two-piece regulating stem which can be used for both control and shut-off. While it is not as precise as the control associated with the MicroMetering stem, especially with smaller flows, it does offer substantially better control than the Vee stem.

Replaceable Seat (with Vee Stem)

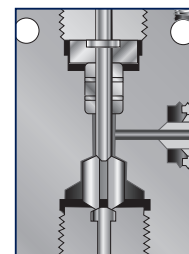

Replaceable seat option is only available with Right-Angle Style body. Replaceable seat is supplied as standard with an additional seat - rotate to use second side. Can be used with either stem type. Options include Stellite material or N-Dura coating to increase service life.

Valve Options: (For Actuator Options please reference specific Actuator brochure)

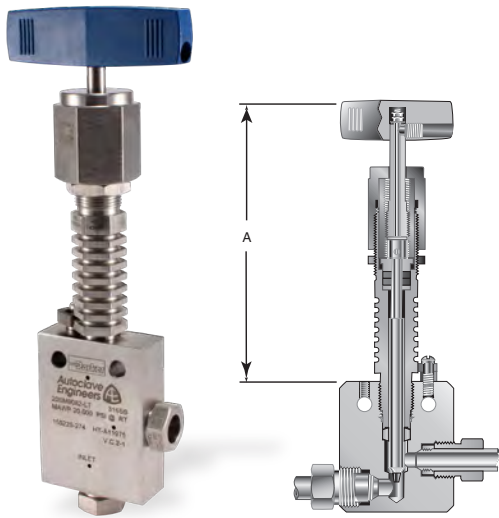

High/Low Temperature Extension:

Not typically needed for 10V/SW Series valves as temperature range does not exceed the barriers below, but option is shown for consideration.

- HT High Temperature (over 800°F (427°C))
- LT Low Temperature (under -100°F (-73°C))

Valve Series	Outside Diameter Tube Size (inches)	Dimensions "A" inches (mm)
10V & SW (this option not typically needed)	1/8"	5.38 (137)
	1/4"	5.50 (140)
	3/8"	5.50 (140)
	9/16"	6.31 (160)

HT option code includes Graphite (-GY) packing
 LT option code includes 316 SS Trim material and PTFE packing

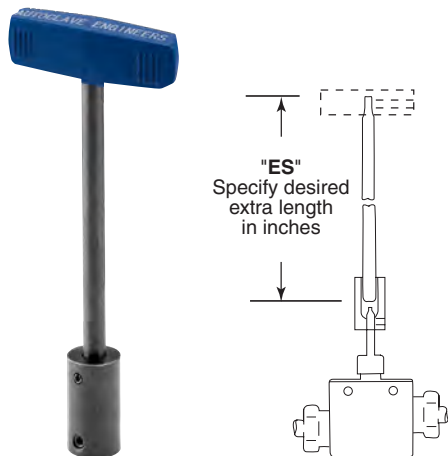

ES Stem Extender:

Stem extenders are offered for High and Low temperature operation or to extend through panel or barricade.

To order valve with Stem Extender, add "ES-" and length (6", 12", 18", 24") to beginning of valve part number e.g. ES12-20SM6071. Other lengths to special order.

To order Stem Extender only, provide valve model prefix e.g. ES12-20SM6. Handle not included – use same provided with original valve.



Needle Valve Clam Shell Handle Lockout:

(order separately using part numbers shown below, padlock not included)

Clam Shell Handle locks are provided to lockout valves in open or closed position preventing unauthorized personnel from actuating valve during shutdown or emergency situations. This clamshell design is available in four (4) sizes dependent on handle length:

- P/N AE004855 – 1" to 2.5" handle length
- P/N 90088 – 2.5" to 5.0" handle length
- P/N 90194 – 6.5" to 10" handle length
- P/N AE004350 – 8" to 13" handle length

Parker Worldwide

AE – UAE, Dubai
Tel: +971 4 8875600
parker.me@parker.com

AR – Argentina, Buenos Aires
Tel: +54 3327 44 4129
falecom@parker.com

AT – Austria, Wiener Neustadt
Tel: +43 (0)2622 23501-0
parker.austria@parker.com

AT – Eastern Europe, Wiener Neustadt
Tel: +43 (0)2622 23501 970
parker.easteurope@parker.com

AU – Australia, Dandenong
Tel: +61 (0)3 9768 5555
customer.service.au@parker.com

AZ – Azerbaijan, Baku
Tel: +994 50 2233 458
parker.azerbaijan@parker.com

BE/LX – Belgium, Nivelles
Tel: +32 (0)67 280 900
parker.belgium@parker.com

BR – Brazil, Sao Jose dos Campos
Tel: +55 12 4009 3504
falecom@parker.com

BY – Belarus, Minsk
Tel: +375 17 209 9399
parker.belarus@parker.com

CA – Canada, Grimsby, Ontario
Tel: +1 905-945-2274
ipd_canada@parker.com

CH – Switzerland, Etoy
Tel: +41 (0) 21 821 02 30
parker.switzerland@parker.com

CL – Chile, Santiago
Tel: +56 (0) 2 2303 9640
falecom@parker.com

CN – China, Shanghai
Tel: +86 21 2899 5000
INGtechnical.china@parker.com

CZ – Czech Republic, Klecany
Tel: +420 284 083 111
parker.czechrepublic@parker.com

DE – Germany, Kaarst
Tel: +49 (0)2131 4016 0
parker.germany@parker.com

DK – Denmark, Ballerup
Tel: +45 43 56 04 00
parker.denmark@parker.com

ES – Spain, Madrid
Tel: +34 902 33 00 01
parker.spain@parker.com

FI – Finland, Vantaa
Tel: +358 (0)20 753 2500
parker.finland@parker.com

FR – France, Contamine s/Arve
Tel: +33 (0)4 50 25 80 25
parker.france@parker.com

GR – Greece, Athens
Tel: +30 210 933 6450
parker.greece@parker.com

HU – Hungary, Budapest
Tel: +36 1 220 4155
parker.hungary@parker.com

ID – Indonesia, Tangerang
Tel: +62 (0)21 7588 1906
parker.id@parker.com

IE – Ireland, Dublin
Tel: +353 (0)1 466 6370
parker.ireland@parker.com

IN – India, Mumbai
Tel: +91 22 6513 7081-85

IT – Italy, Corsico (MI)
Tel: +39 02 45 19 21
parker.italy@parker.com

JP – Japan, Tokyo
Tel: +(81) 3 6408 3900
infophj@parker.com

KR – South Korea, Seoul
Tel: +82 2 559 0400
parkerkr@parker.com

KZ – Kazakhstan, Almaty
Tel: +7 7272 505 800
parker.easteurope@parker.com

LV – Latvia, Riga
Tel: +371 6 745 2601
parker.latvia@parker.com

MX – Mexico, Toluca
Tel: +52 722 275 4200
contacto@parker.com

MY – Malaysia, Selangor
Tel: +603 784 90 800
parkermy@parker.com

NL – The Netherlands, Oldenzaal
Tel: +31 (0)541 585 000
parker.nl@parker.com

NO – Norway, Stavanger
Tel: +47 (0)51 826 300
parker.norway@parker.com

NZ – New Zealand, Mt Wellington
Tel: +64 9 574 1744

PL – Poland, Warsaw
Tel: +48 (0)22 573 24 00
parker.poland@parker.com

PT – Portugal, Leca da Palmeira
Tel: +351 22 999 7360
parker.portugal@parker.com

RO – Romania, Bucharest
Tel: +40 21 252 1382
parker.romania@parker.com

RU – Russia, Moscow
Tel: +7 495 645-2156
parker.russia@parker.com

SE – Sweden, Spånga
Tel: +46 (0)8 59 79 50 00
parker.sweden@parker.com

SG – Singapore,
Tel: +65 6887 6300
parkersg@parker.com

SK – Slovakia, Banská Bystrica
Tel: +421 484 162 252
parker.slovakia@parker.com

SL – Slovenia, Novo Mesto
Tel: +386 7 337 6650
parker.slovenia@parker.com

TH – Thailand, Bangkok
Tel: +66 2 186 7000
phthailand@parker.com

TR – Turkey, Istanbul
Tel: +90 216 4997081
parker.turkey@parker.com

TW – Taiwan, Taipei
Tel: +886 2 2298 8987
enquiry.taiwan@parker.com

UA – Ukraine, Kiev
Tel: +380 44 494 2731
parker.ukraine@parker.com

UK – United Kingdom, Warwick
Tel: +44 (0)1926 317878
parker.uk@parker.com

USA – IPD, Huntsville
Tel: +1 256 881 2040
ipdacct@parker.com

USA – Autoclave Engineers, Erie
Tel: +1 814 860 5700
ipdaect@parker.com

VN – Vietnam, Hochi Minh City
Tel: +84 (0)8337 546 51
parker_viet@parker.com

ZA – South Africa, Kempton Park
Tel: +27 (0)11 961 0700
parker.southafrica@parker.com

! CAUTION !

Do not mix or interchange component parts or tubing with those of other manufacturers. Doing so is unsafe and will void warranty.

Parker Autoclave Engineers Valves, Fittings, and Tools are not designed to interface with common commercial instrument tubing and are designed to only connect with tubing manufactured to Parker Autoclave Engineers AES specifications. Failure to do so is unsafe and will void warranty.

WARNING

FAILURE, IMPROPER SELECTION OR IMPROPER USE OF THE PRODUCTS AND/OR SYSTEMS DESCRIBED HEREIN OR RELATED ITEMS CAN CAUSE DEATH, PERSONAL INJURY AND PROPERTY DAMAGE.

This document and other information from Parker Hannifin Corporation, its subsidiaries and authorized distributors provide product and/or system options for further investigation by users having technical expertise. It is important that you analyze all aspects of your application and review the information concerning the product or system in the current product catalog. Due to the variety of operating conditions and applications for these products or systems, the user, through its own analysis and testing, is solely responsible for making the final selection of the products and systems and assuring that all performance, safety and warning requirements of the application are met. The products described herein, including without limitation, product features, specifications, designs, availability and pricing, are subject to change by Parker Hannifin Corporation and its subsidiaries at any time without notice.

Offer of Sale

The items described in this document are available for sale by Parker Hannifin Corporation, its subsidiaries or its authorized distributors. Any sale contract entered by Parker will be governed by the provisions stated in Parker's standard terms and conditions of sale (copy available upon request).



Instrumentation Products Division
Autoclave Engineers Operation
8325 Hessinger Drive
Erie, PA 16509-4679
Tel: 814 860 5700
Fax: 814 860 5811
www.autoclave.com
www.parker.com/ipdus

Instrumentation Products Division
Autoclave Engineers Operation,
Houston
15340 Vantage Parkway, East
Houston, TX 77032
Tel: 281 987 3828
Fax: 281 987 2318

Parker Hannifin Manufacturing Ltd.
Instrumentation Products Division,
Europe
Riverside Road
Pottlington Business Park
Barnstaple, UK, EX31 1NP, UK
Tel: 44 1271 313131
Fax: 44 1271 373636