

# Custom Valves, Adapters & Manifolds

Parker Autoclave Engineer's offers special components designed to meet customer specific requirements.

The following pages provide a brief outline of our optional connections and valve styles. Other styles of connections are available such as flange, SAE, AE Easy-Union, or metric, upon request.

Manifolds are well suited for particular applications such as termination of common lines as a distribution source from a large line to several smaller ones. Parker Autoclave Engineers manifolds are made to customer specifications and can be rated up to 100,000 psi (6895 bar). Manifolds can be supplied with any number and variety of connections, including our medium and high-pressure connections, NPT, SAE, BSP, clamp-style, and others.

Components are available in non-standard materials, and can be supplied with special testing, cleaning or other requirements.

Specialty components such as adapters and dielectric fittings are available upon request.

Contact your local sales representative for availability and pricing of custom components.



Custom Valves, Adapters & Manifolds



# Custom Valves, Adapters & Manifolds

Parker Autoclave Engineers offers a product line of non-standard valves and fittings with alternate style connections.

## Military Style Connections

According to military standards

- MS16142
- MS33649
- MS33656

Up to 1" (25.4mm) in size.

## Tube or Pipe Socket Weld

Weld connections up to 1" (25.4mm) in size.

## Tube or Pipe Butt Weld

Weld connections up to 1" (25.4mm) in size.

## British Standard Pipe Threads

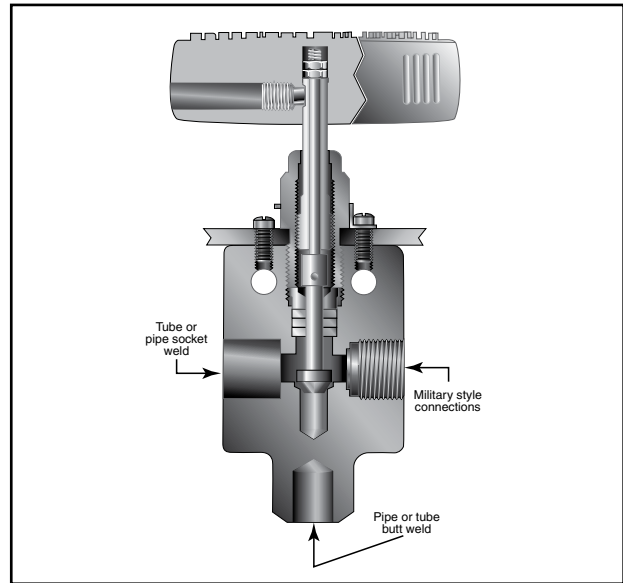

## Special Adapters

Parker Autoclave Engineers also offers a line of components that assist in adapting into and out of specialized connections with Parker Autoclave Engineers medium pressure products. Along with the adapters shown, Parker Autoclave Engineers can provide other special adapters to fill requirements. Contact your local sales representative for information.

### AE Medium Pressure (Male)

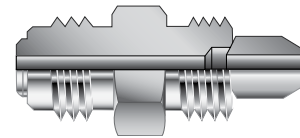

KC105 - 2 Piece

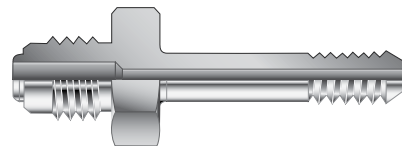

KC105 - 1 Piece

## Dielectric Fittings

Dielectric couplings isolate components from the effects of electrical current. Available as male/female coupling rated to 15,000 psi (1034 bar) with selected connection sizes. For more information contact local sales or the factory

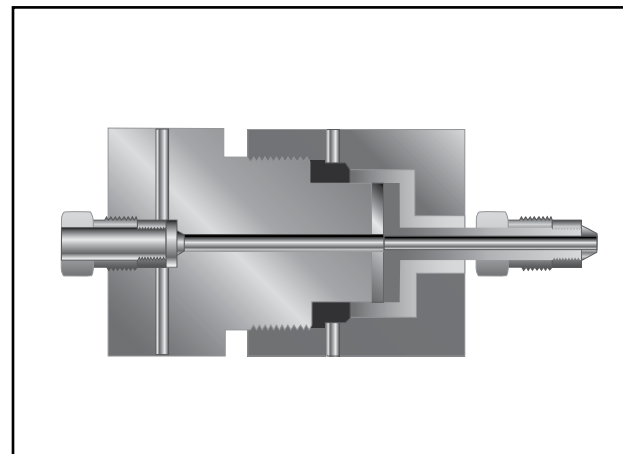

# Custom Valves, Adapters & Manifolds

## Metric, Special Material & Special Configuration Valves, Fittings & Tubing

Parker Autoclave Engineers medium and high pressure valves and fittings are available in a variety of special materials and configurations to satisfy most process requirements. Please refer to the Valve Options section for types of materials available and ordering information.

Other custom valves available include large port valves for ammonia, urea and polyethylene production service, and Y style straight-thru valves designed to minimize pressure drop.

Contact your local sales representative to find out more about these custom products. See the metric section in this catalog for our complete line of metric valves, fitting and tubing line.



## Manifold Block

Specialty pressure manifolds minimize space requirements and reduce the installation time necessary to plumb a pressure system. In addition, by reducing the number of components used in a system, manifolds also reduce the number of potential leak joints. Parker Autoclave Engineers will design and build pressure manifolds to meet specific installation, layout, and pressure requirements. These manifolds are capable of withstanding pressures from vacuum to 100,000 psi (6895 bar), and are available in a variety of materials and sizes. Among the pressure connections that can be incorporated are Parker Autoclave Engineers low, medium and high pressure, NPT, SAE, BSP and others. Transitions in system line sizes and tubing pressure can be accomplished through a specialty manifold. These manifolds are appropriate wherever pressure tubing systems are utilized.



## Clamp Style Manifolds

Parker Autoclave Engineers will design and build manifolds with clamp-type metal to metal seats to meet customer specific applications. Manifolds can be designed with various sizes of clamp type closure are rated in accordance with the maximum rating of the clamp type closure or other connections, whichever is lower. A wide variation of connections can be supplied to meet required applications. These manifolds are used anywhere multiple ports are needed. They are often used on high pressure liquid nitrogen pumping systems or other gas/liquid handling systems requiring high flow capacities with dependable seal integrity.



**WARNING**

**FAILURE, IMPROPER SELECTION OR IMPROPER USE OF THE PRODUCTS AND/OR SYSTEMS DESCRIBED HEREIN OR RELATED ITEMS CAN CAUSE DEATH, PERSONAL INJURY AND PROPERTY DAMAGE.**

This document and other information from Parker Hannifin Corporation, its subsidiaries and authorized distributors provide product and/or system options for further investigation by users having technical expertise. It is important that you analyze all aspects of your application and review the information concerning the product or system in the current product catalog. Due to the variety of operating conditions and applications for these products or systems, the user, through its own analysis and testing, is solely responsible for making the final selection of the products and systems and assuring that all performance, safety and warning requirements of the application are met. The products described herein, including without limitation, product features, specifications, designs, availability and pricing, are subject to change by Parker Hannifin Corporation and its subsidiaries at any time without notice.

**Offer of Sale**

The items described in this document are available for sale by Parker Hannifin Corporation, its subsidiaries or its authorized distributors. Any sale contract entered by Parker will be governed by the provisions stated in Parker's standard terms and conditions of sale (copy available upon request).



**Instrumentation Products Division**  
Autoclave Engineers Operation  
8325 Hessinger Drive  
Erie, Pennsylvania 16509-4679 USA  
PH: 814-860-5700 FAX: 814-860-5811  
www.autoclave.com

Parker Hannifin Manufacturing Ltd.  
**Instrumentation Products Division, Europe**  
Industrial Estate Whitemill  
Wexford, Republic of Ireland  
PH: 353 53 914 1566  
FAX: 353 53 914 1582

**Caution!** Do not mix or interchange parts or tubing with those of other manufacturers. Doing so is unsafe and will void warranty.

**Caution!** Parker Autoclave Engineers Valves, Fittings and Tools are not designed to work with common commercial instrument tubing and will only work with tubing built to Parker Autoclave Engineers AES Specifications. Failure to do so will void warranty.