

STANDARD
GAS BOOSTER
SYSTEMS

Haskel[®]



WHY CHOOSE HASKEL

Comprehensive systems for demanding high-pressure gas transfer and pressurization solutions.

From selection and design to manufacturing and installation, standard packages provide precision and performance for gas transfer, charging and storage applications.

Reliability

Haskel gas boosters are designed with the highest quality for longevity and easy maintenance. Haskel gas boosters use patented seal systems to give a long working life, providing the capability of transferring and pressurising a wide variety of gases.

Regular servicing by Haskel authorized service and repair centers extends the life of your equipment for continued optimum performance and can be carried out alongside planned maintenance programs.

Extensive Range

Haskel offers single acting, double acting and two stage models to cover a wide range of operating conditions up to pressures of 20,000 PSI (1379 Bar).

GAS BOOSTER SYSTEM FEATURES

- Pressurize gas from industrial gas bottles (up to 20,000 psi)
- Plumbed for inert gases in single arrangements
- Available in single-stage or two stage styles; selection is made on the grounds of gas pressure and flow requirements
- Supplied with a range of controls: air controls, air pilot switches (optional) for automated stop/start control, relief device, pressure isolation and vent valves
- All components are mounted and plumbed in an open stainless steel frame with a sloped front control panel
- Safety relief devices are standard on all gas booster systems for maximum operational safety
- Allows 90 to 95% use of cylinder gas to maintain process pressure when cylinder pressure drops
- Oxygen Cleaned units available
- Can charge a receiver to even higher-pressure level, thus storing a volume of gas for rapid release

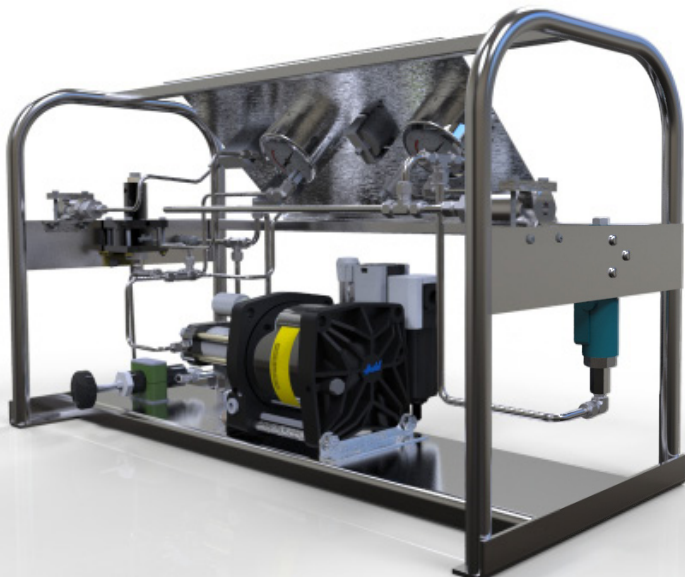

APPLICATIONS

Gas accumulator charging

Pressure & leak testing various pressure containing components

Pressurization of gas cylinders

Gas transfer, boosting or mixing

SCOPE OF SUPPLY

1. Air driven gas booster with external pilot air modification to enable use of external air pilot switches to automatically start and stop the booster.
2. Adjustable inlet air pilot switch used to stop booster when the gas supply pressure falls below the adjusted minimum set point (optional).
3. Adjustable remote-set outlet air pilot switch used to stop booster when the outlet pressure reaches the adjusted maximum set point (optional).
4. Outlet pressure gauge, safe case design, 100mm diameter, panel mounted with bar/psi dual scale. Accuracy +/- 1% FSD.
5. Inlet pressure gauge, safe case design, 100mm diameter, panel mounted with bar/psi dual scale. Accuracy +/- 1% FSD.
6. Gas filter, 5 micron rated, used to stop any ingested contamination from entering the booster (e.g. while changing out gas supply bottles).
7. Roll bar frame with sloping operator panel into which the booster and controls are mounted. Frames are a brushed 316 stainless steel.
8. Combined air inlet filter regulator, with integral pressure gauge and on/off control valve. Air filter – in line with 40-micron filtration to maintain air drive quality. Adjustable air regulator used to set the air drive pressure, adjustable between 0 – 150 PSI. 25mm air gauge indicated the regulated air pressure setting. Manual on/off valve and speed control valve, panel mounted, used to adjust the cycling speed at which the booster operates.
9. Adjustable Haskel relief valve used to protect the booster and other components from over pressurization, piped to a common vent connection.
10. Adjustable remote-set air pilot regulator used to change the set point for the remote set outlet air pilot switch (optional).
11. 25mm air gauge, panel mounted, used to indicate the adjustable remote set regulator adjusted pressure.
12. Manually operated BuTech outlet isolation valve, panel mounted, piped to a common vent connection.
13. Manually operated BuTech outlet pressure vent valve, panel mounted, piped to a common vent connection.
14. Interstage cooler. A Haskel design integral tube and shell cooler used to reduce the boosted gas temperature.

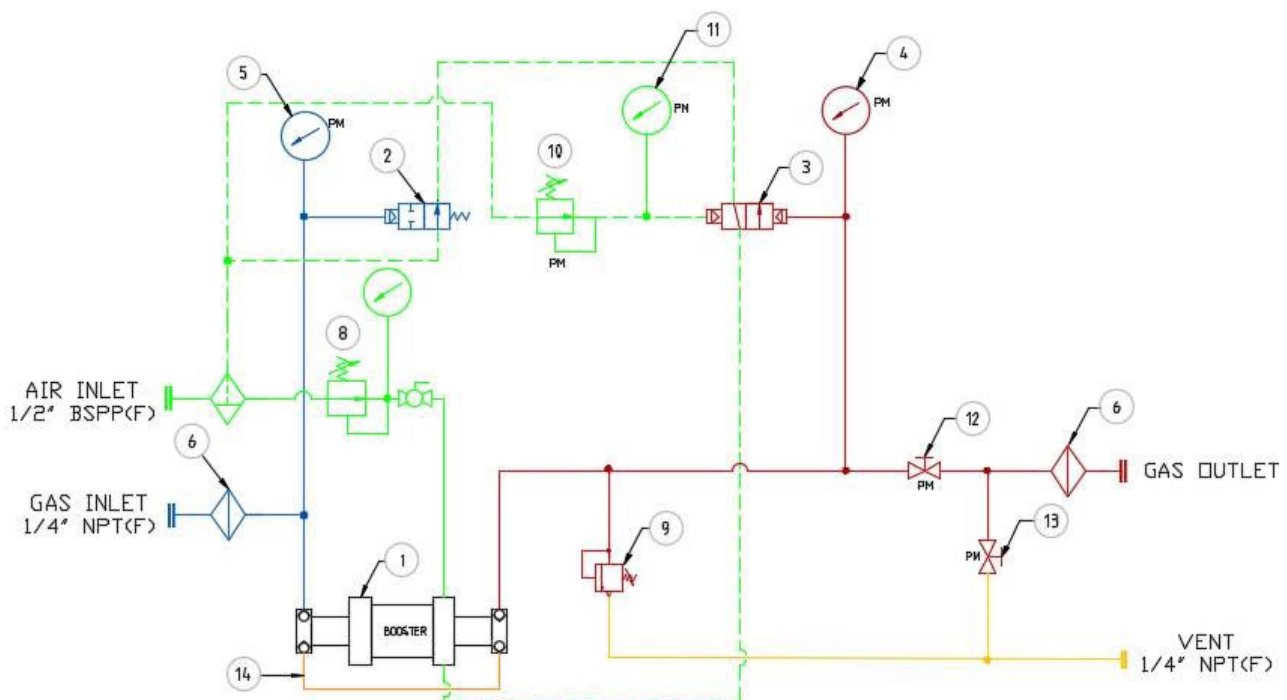

⑦ ROLL BAR FRAME & PANEL



INNOVATION THAT SHAPES THE FUTURE

Haskel leads the world in the design, manufacture, and supply of high-pressure fluid power solutions. We continue to shape the future of the industry by working closely with customers to meet advancing needs.

Global Coverage and Aftermarket Support

Haskel, an international organization, offers world-wide service through a global network of factory trained authorized service and repair centers.

Quality

Our quality system is based on a commitment to customer satisfaction and continuous improvement. Global accreditations include ISO Management systems, ATEX, CE and more.

Technical Support

We offer extensive product and application knowledge to provide complete solutions, backed by our international network of highly trained distributors with thorough engineering experience.

Proven Technology

Our unrivaled 70-year reputation for safety, quality, performance and innovation is the foundation of all Haskel products.

CONTACT

Haskel International, LLC.

100 East Graham Place
Burbank, CA 91502 USA

Tel: 818-843-4000

Fax: 818-556-2549 or 818-841-4291

Email: sales@haskel.com

Haskel Middle East

P.O. Box 262384 Jebel Ali,
Dubai, United Arab Emirates

Tel: 971-4886-2686

Fax: 971-4886-2684

Email: sales@haskel.com

Haskel Europe Ltd.

North Hylton Road
Sunderland, SR5 3JD, England UK

Tel: 44-191-549-1212

Fax: 44-191-549-0911

Email: saleseurope@haskel.com

Haskel Asia

510 Thomson Road, #13-01,
SLF Building

Singapore 298135

DID: 6568 2842

Tel: 65-6455-7559

Fax: 65-6455-2841

Email: sales@haskel.com