

CIRCLE SEAL CONTROLS

ATKOMATIC SOLENOID VALVES

INSTALLATION, MAINTENANCE, AND OPERATION INSTRUCTIONS

JJ SERIES, Bronze, Normally Closed, Pilot Operated

Installation Instructions

WARNING: These instructions should be read, understood, and followed before installation. Failure to do this can be extremely dangerous and cause valve malfunction.

1. An adequate filter system must be installed in the line ahead of each valve to prevent foreign matter from damaging the seal faces and/or obstructing the valve orifices causing operational failure and leakage. A maximum rating of such a filter is 40 microns to provide adequate protection.
2. Pipe thread sealing compounds and tape must be prevented from entering the valve.
3. New systems must be adequately flushed to remove all pipe scale, weld slag, thread burrs, etc. It is typically necessary to flush new systems several times, removing contamination lodged in filters and other components, until no debris is present.
4. Valves must be installed in a horizontal line with the coil oriented up (within +/- 10 degrees).
5. Mount the valve in the line such that the arrow cast into the valve body is in the direction of flow.
6. Check the nameplate and provide the specified voltage to the coil. Voltages must be as specified at the coil rather than the power supply. This is particularly important with DC applications due to their typically high voltage drop through supply lines. All AC coils are for single phase use only.
7. Coil housings may be rotated as required to match up with supply wiring. This is done by loosening the screw at the top center of the coil housing, rotating the coil housing assembly, and re-tightening the coil housing screw. Do not splice the lead wires inside the coil housing.
8. Valve should be mounted a minimum of 6 feet from a pressure regulator.
9. Use the valve only on the fluid, voltage, and pressure specified on the nameplate.

CAUTION: Valves should be handled carefully during installation with care taken to prevent damage to the cylinder cap tube inside the coil housing. Do Not tighten the valve in the line by applying pressure or torque to the coil housing. Use the wrench flats on either end of the valve body.

Maintenance Instructions

CAUTION: Only qualified maintenance personnel should work on the valve. If the valve is within the warranty period, do not disassemble without approval from the factory Returned Materials Department.

WARNING: Normal coil operating temperatures are high enough to cause severe burns – DO NOT TOUCH HOT COILS OR COIL HOUSING WITHOUT ADEQUATE PROTECTION.

Coil Replacement

WARNING: Turn off electrical power to the coil

1. Disconnect the coil's electrical leads.
2. Loosen the cap screw and remove the nameplate.
3. Remove the coil hold down spring, and the upper end plate.
4. Pull the coil and can assembly off of the cylinder cap tube.
5. Separate the coil from the coil can.
6. Remove the upper and lower end plates from the coil.
7. Replace the coil and reinstall the parts in their original order.

CAUTION: Do not apply voltage to the coil until it is installed in the completely assembled housing.

CAUTION: Be certain that all coil housing parts are reinstalled. Failure to install end plates, coil can, or hold down spring will result in coil burn-out.

Note: All coils, including AC and DC types, can be used interchangeably in the JJ series valves without changing any other parts. Operational pressures are lower with DC coils.

Cleaning or Replacement of Internal Parts

WARNING: Turn off electrical power to the coil and reduce the line pressure to 0 psi before beginning disassembly.

1. Remove the cap screw and lift the entire coil housing off of the body & cylinder cap.
2. Unscrew the cylinder cap from the valve body and lift it from the body. This will expose the plunger assembly which can be held with one hand while lifting the cylinder cap with the other hand.
3. The piston assembly can be pulled out of the valve body bore.

Note: The 2" JJ valves have a plate underneath the cylinder cap which is removed before the piston is exposed. **NOTE: this size valve is no longer available.**

4. Inspect all components.
5. Clean and replace components as required

CAUTION: When cleaning out bleed and seat screw orifices, do not ream the out to larger diameters as this will upset the pressure balance within the valve and prevent proper operation.

Warning: Inspect all o-rings. Worn o-rings should be replaced. Failure to do this can result in external valve leakage and be extremely dangerous.

CAUTION: Replacement piston rings must have the same gap as the original rings. Failure to properly gap the piston rings can cause the valve to malfunction.

Note: Repair kits contain the complete plunger assembly.

Troubleshooting

1. Valves has trouble opening

- Is the fluid clean and free of contamination?
- Is the valve mounted in a horizontal line with the coil on top?
- Is the valve installed in the proper flow direction as indicated by the arrow cast into the body or “in” and “out” stamps?
- Is the voltage applied correct?
- Is the voltage within +/- 10% of the nominal?
- Is the voltage measured at the coil and with the valve energized? This is particularly important on DC applications.
- Is the flow sufficient to produce a pressure drop of 3 to 5 psig?
- Is the ambient temperature above 104 F?
- Is the fluid more viscous than 150 SUS?
- Is there an audible click when the valve is energized? This indicated pilot operation. If no click is audible, check for contamination and/or bent or dented pilot tube.
- Is the fluid the same as that indicated on the nameplate?
- Has the pilot orifice become clogged with contaminates?
- Is there 100% back pressure (downstream piping shutoff) on the valve?

2. Valve has trouble closing

- Is the fluid clean and free of contamination?
- Is the valve being used for the same type of fluid for which it was built?
- Is the valve mounted in a horizontal line with the coil on top?
- Is the voltage within +/-10% of nominal?
- Is there a regulator or other flow restriction upstream of the valve?
- Is the valve installed in a horizontal line with the coil on top?
- Is the valve actually not closing or closing very slowly or leaking excessively?
- Is there foreign matter lodged under the valve seat?
- Is the fluid more viscous than 150 SUS?
- Has the piston spring been removed from the valve?
- Have the piston rings been damaged during re-assembly?
- Have the expander rings beneath the piston rings been removed or damaged?
- Is there 100% back pressure (downstream piping shutoff) on the valve or does the downstream system pressure exceed the valve's inlet pressure?
- Has the bleed orifice(s) in the piston become clogged with foreign material?
- Has the disc seat in the piston become worn or damaged?
- Has the valve stem become worn or damaged?
- Is the valve actually closing but leaking excessively?

3. Valve is leaking internally

- Is there any contamination in the fluid?
- How much is the leakage and at what pressure? If the leak is excessive it could be caused by a bent or dented pilot tube. If the leak is small, how does it compare with the factory leakage standard?
- Is the fluid chemically compatible with the Buna-N seat material?
- Is the temperature of the fluid within the limits of the Buna-N seat material?
- Is the valve mounted in a horizontal line with the coil on top?

4. Coil has burnt out

- Is the voltage applied correct?
- Is the voltage within +/- 10% of the nominal?
- Is the ambient temperature above 40 C (104 F)?
- Is adjacent equipment or piping radiating excessive heat to the valve or raising the air surrounding the coil above 104F?
- Is the fluid temperature above that for which the valve is rated?
- Is the valve's coil housing assembled correctly? Has the customer opened up the coil housing? Are the end plates installed and oriented correctly? Has the coil hold-down spring been reinstalled?
- Have the coil leads been cut or damaged in handling or installation?
- Is contamination or physical binding preventing the plunger from actuating? This will cause an AC coil to burn out. Monitoring the AC current draw and comparing the measured value to the holding current given in the catalog can check the presence of this condition.
- Is the cycle rate excessive?
- Is the valve mounted in an enclosure that prevents free circulation of the ambient air?
- Was the coil failure immediate or did the burnout take hours or days? If immediate, the coil may have been defective or damaged and have shorted internally.

5. Valve leaks externally

- Has the valve been disassembled? The body o-rings are frequently Teflon and may require replacement to reseal.
- Is the bonnet nut or cylinder cap adequately torqued?
- Is the fluid chemically compatible with the seal material?
- Is the temperature of the fluid within the limits of the seat material?
-

6. Valve wears out quickly

- What is the cycle rate?
- Is the valve chattering or internal pilot stem & seat wearing rapidly (gas application)?
- Is there a regulator upstream of the valve (gas application)?
- Is the fluid contaminated with an abrasive material?
- Is the ambient or fluid temperature excessive?
- Is the fluid chemically compatible with the seal material?
- Is the temperature of the fluid within the limits of the seat material?
- What is the customer's definition of premature wear?

Contamination in fluid systems is the largest single cause of operational problems. Frequently contamination is present in new systems from sources such as pipe sealant, pipe scale, weld slag, and metallic particles from the assembly of pipe fittings. Flushing of new systems is important to reduce the occurrence of problems, however often even through flushing will not eliminate all contaminants that will break loose during the initial operation of a new system. Filters are an essential component in many systems to prevent valve problems. It is important to locate filters immediately upstream of the valves and to size the filter rating correctly. A maximum micron rating to provide adequate protection is 40 microns. Note that strainers or screens are generally not capable of providing this degree of filtration and a filter with a depth type of element is necessary.

Standard Available Coils

Class B Coils for JJ Series Valves

<u>Voltage</u>	<u>Part Number</u>	<u>Resistance +/-10%</u>	<u>Inrush Amps</u>	<u>Holding Amps</u>	<u>Volt-Amps</u>
24 VAC 60 Hz	62197	6.51 Ohms	2.11	0.99	51
110 VAC 50 Hz	62191	232.5	0.35	0.17	39
115 VAC 60 Hz	62209	156.4	0.43	0.21	49
220 VAC 50 Hz	62193	955.2	0.17	0.084	37
230 VAC 60 Hz	62199	639.2	0.21	0.10	48
460 VAC 60 Hz	62201	2517	0.108	0.050	50
12 VDC	62203	9.63		1.26	15
24 VDC	62205	39.67		0.60	15
100 VDC	62199	639.2		0.20	20

Class H Coils for JJ Series Valves

<u>Voltage</u>	<u>Part Number</u>	<u>Resistance +/-10%</u>	<u>Inrush Amps</u>	<u>Holding Amps</u>	<u>Volt-Amps</u>
24 VAC 60 Hz	62198	6.48	2.10	0.96	50
100 VAC 60 Hz	63599	101.4	0.68	0.35	68
110 VAC 50 Hz	62190	187.6	0.39	0.17	43
115 VAC 60 Hz	62210	140.1	0.52	0.25	60
200 VAC 60 Hz	63600	408.4	0.34	0.17	68
220 VAC 50 Hz	62194	903.0	0.18	0.085	40
230 VAC 60 Hz	62200	498.3	0.31	0.10	71
380 VAC 50 Hz	62202	1980	0.16	0.075	74
460 VAC 60 Hz	62202	980	0.16	0.075	74
550 VAC 60 Hz	64655-1	3510	0.10	0.05	55
6 VDC	62204	2.57		2.2	13
12 VDC	62206	10.17		1.13	14
24 VDC	62186	40.82		0.58	14
32 VDC	62186	40.82		0.74	24
48 VDC	62210	140.1		0.40	19
100 VDC	62200	498.3		0.20	20
125 VDC	62188	706.0		0.17	21
250 VDC	62192	2986		0.08	20

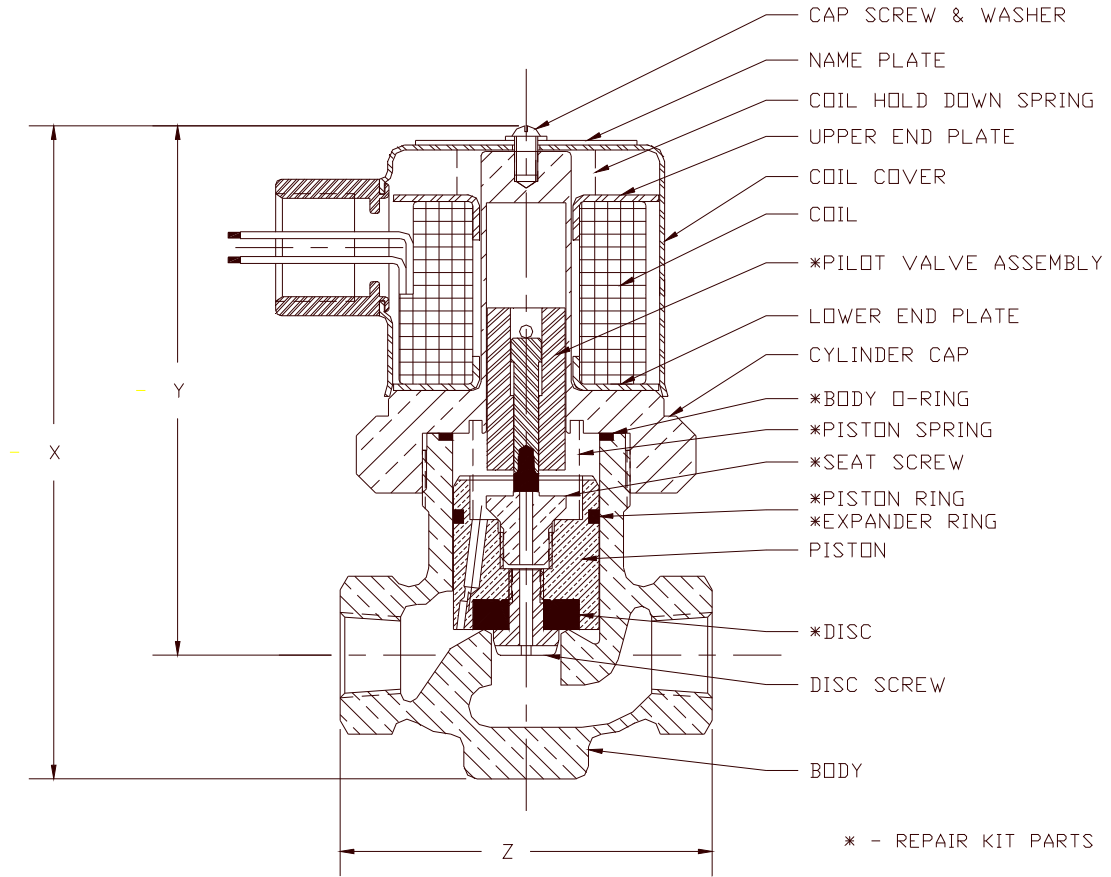

Shown is a 3/8" JJ300 valve

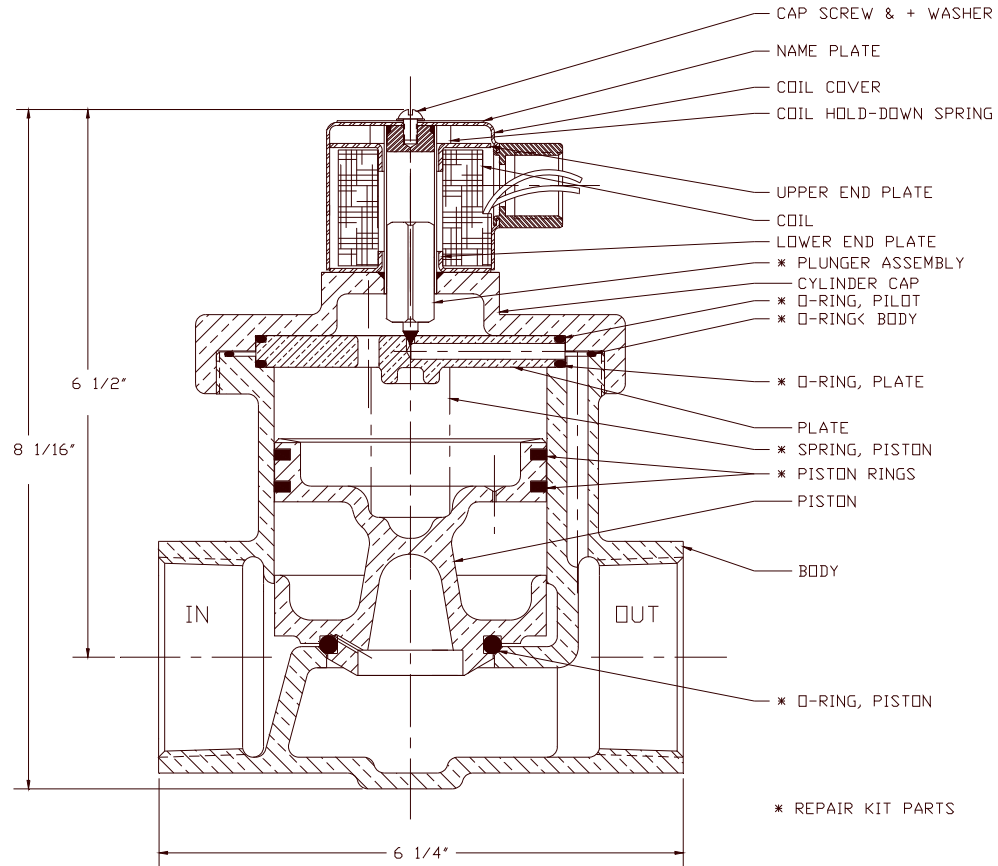

Shown is a 2" JJ900 valve (NOTE: this size is no longer available.)

Parts that comprise standard repair kits are identified in the cross section above. Repair kit numbers are the valve model number preceded by a K/. For instance the repair kit for a JJ200-30HP valve is K/JJ200-30HP. All other valve parts are available for repair purposes. When ordering specify the parts desired by description the complete 9 digit catalog number. If the catalog number is unavailable, and specify: 1) the valve base model, 2) the pipe size, 3) fluid, 4) operational pressure (minimum and maximum), voltage and frequency, 5) temperature if different from ambient, and 6) any special requirements.

Dimensions, Shipping Weights, and Cv Flow Factors

Catalog Number Prefix	Pipe Size	Main Seat Orifice Dia	X	Y	Z	Shipping Weight (lbs.)	Cv
JJ200	1/4"	1/2"	4 3/4"	3 7/8"	2 11/16"	3	1.4
JJ300	3/8"	1/2"	4 3/4"	3 7/8"	2 11/16"	3	2.7
JJ400	1/2"	1/2"	4 3/4"	3 7/8"	3"	4	3.5
JJ500	3/4"	1"	5 1/4"	4"	3 3/4"	5	7.5
JJ600	1"	1"	5 1/4"	4"	3 3/4"	5	9.1
JJ700	1 1/4"	1 1/2"	7"	5 1/8"	5 1/16"	13	19.5
JJ800	1 1/2"	1 1/2"	7"	5 1/8"	5 1/16"	13	21.0
JJ900	2"	2"	8 1/16"	6 1/2"	6 1/4"	16	46.0

The JJ900 is no longer available.

Operation

Opening

When voltage is applied across the coil leads a current is produced in the coil windings which generates a magnetic field. The magnetic field attracts the plunger and causes it to move toward the center of the coil or magnetic stop. Initially the plunger slides freely on the stem until it impacts the nut or shoulder at the end of the stem. The plunger's momentum is then transferred to the stem and the stem is lifted off the seat screw pilot orifice. Fluid from the cavity above the piston flows through the pilot orifice in the seat screw and through the drilled hole in the center of the piston to the downstream side of the valve. Pressure above the piston decreases since the pilot orifice is larger in diameter than the bleed orifice. Inlet pressure acting around the annular area outside of the main valve seat at the bottom of the piston then pushes the piston up, thus initiating flow through the valve.

Note that flow through the valve creating a pressure drop across the valve is required to hold the piston open. If flow is diminished the piston will move toward the closed position. To maintain the valve fully open a pressure drop of 3 to 5 psid across the valve is required.

Closing

When voltage is removed from the coil leads, the magnetic field collapses. Gravity pulls both the plunger and stem down until the stem point seals off the pilot orifice. Fluid flow from the valve's inlet side through the bleed orifice in the piston charges the cavity above the piston to a pressure equal to the valve's inlet pressure. Since downstream pressure is acting against the center portion of the bottom of the piston, the pressure forces acting on the piston are unbalanced and act to push the piston to the closed position (gravity and, with some valves, a piston spring assists in the closing).

We manufacture a complete line of rugged dependable solenoid operated valves for pressure ranging from 0 to 10,000 psi.

**Download a complete catalog of the Atkomatic Valve Product Line from
<http://www.circle-seal.com/Atkomatic.html>**

**Circle Seal Controls
Atkomatic Product
2301 Wardlow Cir.
Corona, CA 92880**