

ATKOMATIC

6000 Series

Bronze, Pilot-piston, Pressure 0 to 1500 psig (0.4 to 103.5 bar)
Medium Pressure Valve Configurable for Variety of Fluid Applications



atkomatic solenoid

Features

- Pressures to 1500 psig (103.5 bar)
- Pilot operated: require a minimum pressure differential of 5 psig (0.4 bar)
- Full ported valves
- Fluid temperatures from -423°F to $+500^{\circ}\text{F}$ (-253°C to $+260^{\circ}\text{C}$)
- For use with any gas or liquid (max. viscosity of 200 SSU), including steam and cryogenic, that is not harmful to bronze
- Pipe sizes of $\frac{1}{4}$ " through $1\frac{1}{2}$ " (British BSPT ports available)
- Cv from 1.4 to 21
- Available in normally open and normally closed versions
- Optional pilot & piston seat seal materials of Teflon®, PCTFE, Buna N, Viton®, EPR, or metal (316 stainless steel pilot & brass piston seat) depending on fluid type and pressure
- Body seal materials of Teflon®, Viton®, Buna N, or EPR.
- Bronze valve material (naval M bronze)
- Removable 316 stainless steel body inserts (stainless steel trim)
- Coil housings available in NEMA 1 (standard), NEMA 4 (waterproof), NEMA 7 (explosion-proof for hazardous locations), and combination NEMA 4 & 7
- Manual opening and throttling devices are available as options
- Class B coils are available for media temperatures of 0°F (-18°C) through $+220^{\circ}\text{F}$ (104°C) (available on both normally closed and normally open valves)
- Class H coils are available: recommended for media temperatures of -423°F (-253°C) through $+500^{\circ}\text{F}$ ($+260^{\circ}\text{C}$) (available on both normally closed and normally open valves)
- Treated 416 stainless steel plunger material for increased corrosion resistance

Circle Seal Controls

2301 Wardlow Circle • P.O. Box 3300 • Corona, CA 92880

Phone (951) 270-6200 Fax (951) 270-6201

www.circle-seal.com • am_sales@circle-seal.com • ind_sales@circle-seal.com

6000 Series

Operational Pressures (5 psid minimum pressure differential)

Normally closed 6000–6200 ¼" through ½"

GASES		LIQUIDS TO 40 SUS		LIQUIDS OVER 40 SUS		STEAM	
AC	DC	AC	DC	AC	DC	AC	DC
1500	1500	1500	1000	1,200	600	200	200

Normally closed 6300–6600 ¾" through 1½"

GASES		LIQUIDS TO 40 SUS		LIQUIDS OVER 40 SUS		STEAM	
AC	DC	AC	DC	AC	DC	AC	DC
1000	1000	1000	1000	1000	600	200	200

Normally open 6001–6201 ¼" through ½"

GASES		LIQUIDS TO 40 SUS		LIQUIDS OVER 40 SUS		STEAM	
AC	DC	AC	DC	AC	DC	AC	DC
1500	1000	1000	500	1000	350	200	200

Normally open 6301–6601 ¾" through 1½"

GASES		LIQUIDS TO 40 SUS		LIQUIDS OVER 40 SUS		STEAM	
AC	DC	AC	DC	AC	DC	AC	DC
1000	1000	1000	500	1000	350	200	200

Note: Normally open 6001 Series valves are rated for intermittent duty only, unless other operational parameters are at their nominal values.

Note: Buna N, Viton® and EPR seats are limited to 500 psi (34.5 bar)

Dimensions, Shipping Weights, and Cv Flow Factors

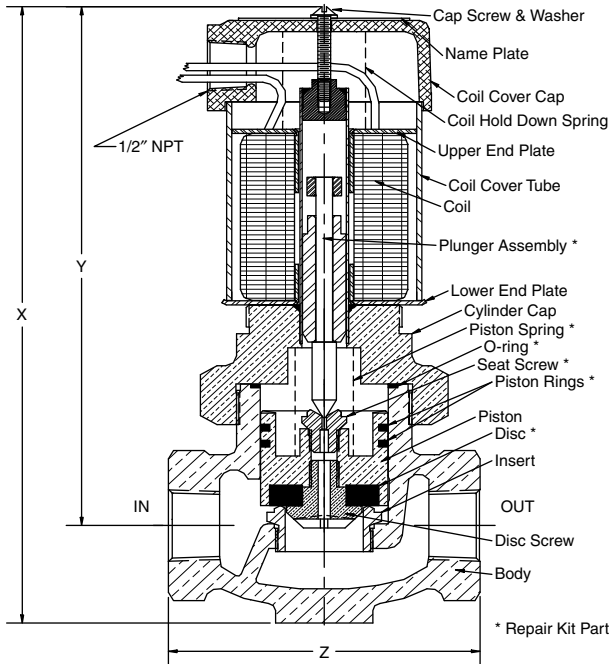

Normally closed 1" 6400 valve, shown with a NEMA 1 coil housing and a metal pilot seat

Normally Closed

CATALOG NUM.	PIPE SIZE	MAIN SEAT ORIFICE	X	Y	Z	SHIPPING WEIGHT (lbs)	Cv
6000	¼"	⅜"	7⅞"	6¼"	2⅛"	6	1.4
6100	⅜"	⅜"	7⅞"	6¼"	2⅛"	6	2.7
6200	½"	½"	7⅞"	6¼"	3"	8	3.5
6300	¾"	1"	8¼"	7"	4"	9	8.4
6400	1"	1"	8¼"	7"	4"	9	9.5
6500	1¼"	1½"	9⅜"	8"	5⅛"	15	19.5
6600	1½"	1½"	9⅜"	8"	5⅛"	15	21.0

Normally Open

CATALOG NUM.	PIPE SIZE	MAIN SEAT ORIFICE	X	Y	Z	SHIPPING WEIGHT (lbs)	Cv
6001	¼"	⅜"	8⅞"	7¼"	2⅛"	6	1.4
6101	⅜"	⅜"	8⅞"	7¼"	2⅛"	6	2.7
6201	½"	½"	8⅞"	7¼"	3"	8	3.5
6301	¾"	1"	9⅞"	8⅜"	4"	9	8.4
6401	1"	1"	9⅞"	8⅜"	4"	9	9.5
6501	1¼"	1½"	11"	9⅜"	5⅛"	15	19.5
6601	1½"	1½"	11"	9⅜"	5⅛"	15	21.0

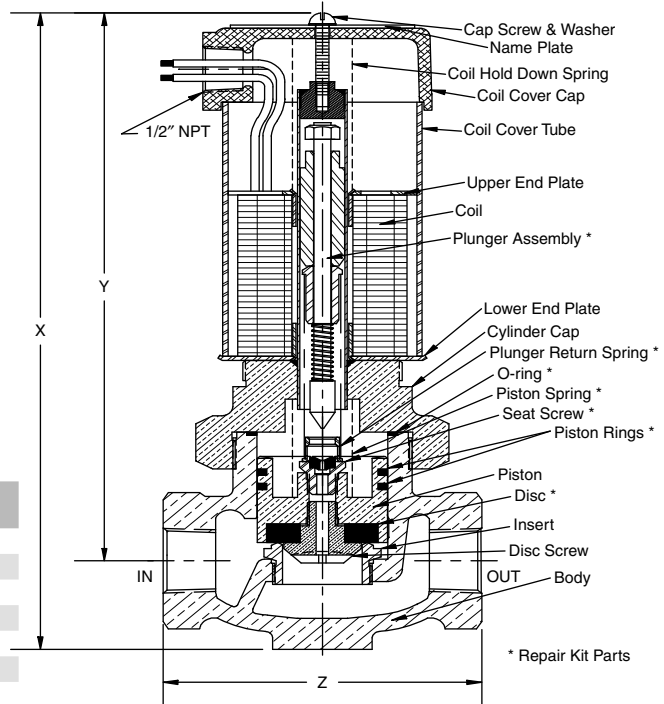

Normally open 1" 6401 valve, shown with a NEMA 1 coil housing and a soft pilot seat

6000 Series

How to Order

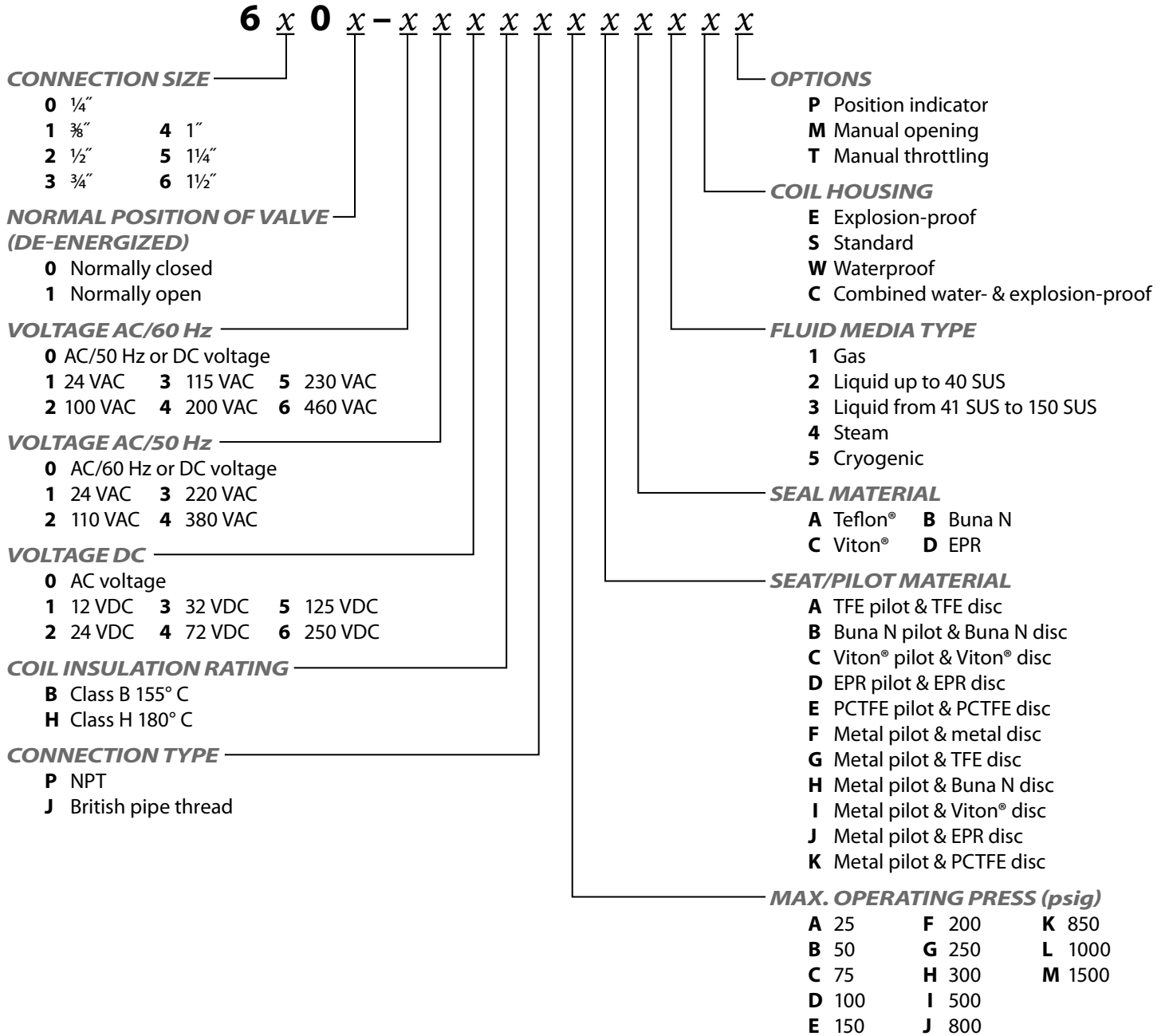

Viton® is a registered trademark of DuPont Dow Elastomers.
Teflon® is a registered trademark of DuPont.