

# CIRCLE SEAL CONTROLS

## ATKOMATIC SOLENOID VALVES

### INSTALLATION, MAINTENANCE, AND OPERATION INSTRUCTIONS

#### BRONZE NORMALLY CLOSED SEMI-DIRECT LIFT VALVES 31400 SERIES

##### Installation Instructions

**WARNING: These instructions should be read, understood, and followed before installation. Failure to do this can be extremely dangerous and cause valve malfunction.**

1. An adequate filter system must be installed in the line ahead of each valve to prevent foreign matter from damaging the seal faces and/or obstructing the valve orifices causing operational failure and leakage. A maximum rating of such a filter is 40 microns to provide adequate protection.
2. Pipe thread sealing compounds and tape must be prevented from entering the valve.
3. New systems must be adequately flushed to remove all pipe scale, weld slag, thread burrs, etc. It is typically necessary to flush new systems several times, removing contamination lodged in filters and other components, until no debris is present.
4. Valves must be installed in a horizontal line with the coil oriented up (within +/- 10 degrees).
5. Mount the valve in the line such that the arrow cast into the valve body is in the direction of flow.
6. Check the nameplate and provide the specified voltage to the coil. Voltages must be as specified at the coil rather than the power supply. This is particularly important with DC applications due to their typically high voltage drop through supply lines. All AC coils are for single phase use only.
7. Coil housings may be rotated as required to match up with supply wiring. This is done by loosening the housing nut at the top center of the coil housing, rotating the coil housing assembly, and re-tightening the coil housing nut. Do not splice the lead wires inside the coil housing.

Note: On valves equipped with combination explosion proof and waterproof housings, the silicone seal bead must be replaced after adjusting the housing to maintain the integrity of the water proof housing.

8. Valve should be mounted a minimum of 6 feet from a pressure regulator.
9. Use the valve only on the fluid, voltage, and pressure specified on the nameplate.
10. To prevent slow valve operation caused by water loading, it is recommended that a steam trap be installed upstream of all valves used on steam service.

**CAUTION: Valves should be handled carefully during installation with care taken to prevent damage to the cylinder cap tube inside the coil housing. Do Not tighten the valve in the line by applying pressure or torque to the coil housing. Use the wrench flats on either end of the valve body.**

## Maintenance Instructions

**CAUTION: Only qualified maintenance personnel should work on the valve. If the valve is within the warranty period, do not disassemble without approval from the factory Returned Materials Department.**

**WARNING: Normal coil operating temperatures are high enough to cause severe burns – DO NOT TOUCH HOT COILS OR COIL HOUSING WITHOUT ADEQUATE PROTECTION.**

### **Coil Replacement**

**WARNING: Turn off electrical power to the coil**

1. Disconnect the coil's electrical leads.
2. Loosen the housing nut and remove the nameplate and coil housing cover (explosion proof housing covers are threaded).
3. Pull the coil and can assembly off of the cylinder cap tube.
4. DC only, remove the upper end plate.
5. Separate the coil from the coil can.
6. AC only, remove the coil from the laminated steel yoke.
7. Replace the coil and reinstall the parts in their original order.

**Note:** On valves equipped with combination explosion proof and waterproof housings, the silicone seal bead must be replaced after adjusting the housing to maintain the integrity of the water proof housing.

**CAUTION: Do not apply voltage to the coil until it is installed in the completely assembled housing.**

**CAUTION: Be certain that all coil housing parts are reinstalled. Failure to install end plates, coil can, or yoke will result in coil burn-out.**

**Note:** AC coils can be replaced with DC coils by removing and discarding the coil yoke and adding a upper end plate p/n 61104 (13029) above the coil.

**Note:** DC coils can be replaced with AC coils by removing and discarding the upper end plate above the coil and adding the coil yoke p/n 61041 (13100) around the coil. See the caution below.

**CAUTION: When changing from DC to AC operation it is also necessary to install shading rings in the plunger and magnetic stop in the cylinder cap. This requires the use of special tools at the factory. Without this modification the valve will produce a loud AC hum and will eventually wear the plunger.**

### **Cleaning or Replacement of Internal Parts**

**WARNING:** Turn off electrical power to the coil and reduce the line pressure to 0 psi before beginning disassembly.

**WARNING:** On models 31570, 31580, & 31590 carefully loosen bolts on the flange to allow any pressure trapped in the valve to bleed off before removing the nuts from the bolts.

1. Remove the housing nut and lift the entire coil housing off of the body & cylinder cap.
2. Unscrew the cylinder cap from the valve body and lift it from the body. This will expose the plunger assembly which can be held with one hand while lifting the cylinder cap with the other hand.
3. The piston assembly can be pulled out of the valve body bore.
4. Inspect all components.
5. Clean and replace components as required.

**CAUTION:** When cleaning out bleed and seat screw orifices, do not ream them out to larger diameters as this will upset the pressure balance within the valve and prevent proper operation.

**Warning:** Inspect all o-rings. Worn o-rings should be replaced and all Teflon o-rings (white in color) should be replaced as they are not reusable. Failure to do this can result in external valve leakage and be extremely dangerous.

**CAUTION:** Replacement piston rings must have the same gap as the original rings. Failure to properly gap the piston rings can cause the valve to malfunction.

**CAUTION:** Attempting to take apart the stem assembly after its removal from the plunger is not recommended. The threaded parts of the stem assembly are not reusable and building it requires the use of special tools at the factory.

**Note:** Repair kits contain the complete stem assembly.

## Troubleshooting

### 1. Valves has trouble opening

- Is the fluid clean and free of contamination?
- Is the valve mounted in a horizontal line with the coil on top?
- Is the valve installed in the proper flow direction as indicated by the arrow cast into the body or “in” and “out” stamps?
- Is the voltage applied correct?
- Is the voltage within +/- 10% of the nominal?
- Is the voltage measured at the coil and with the valve energized? This is particularly important on DC applications.
- Is the end plate installed above the coil in the coil housing (DC only)?
- Is the ambient temperature above 104 F?
- Is there an audible click when the valve is energized? This indicated pilot operation. If no click is audible, check for contamination and/or bent or dented pilot tube.
- Is the fluid the same as that indicated on the nameplate?
- Has the pilot orifice become clogged with contaminates?
- Is there 100% back pressure ( downstream piping shutoff ) on the valve?

### 2. Valve has trouble closing

- Is the fluid clean and free of contamination?
- Is the valve being used for the same type of fluid for which it was built?
- Is the valve mounted in a horizontal line with the coil on top?
- Is the voltage within +/- 10% ?
- Is there a regulator or other flow restriction upstream of the valve?
- Is the valve installed in a horizontal line with the coil on top?
- Is the valve actually not closing or closing very slowly or leaking excessively?
- Is there foreign matter lodged under the valve seat?
- Is the fluid more viscous than 150 SUS?
- Has the piston spring been removed from the valve?
- Have the piston rings been damaged during re-assembly?
- Have the expander rings beneath the piston rings been removed or damaged?
- Is there 100% back pressure ( downstream piping shutoff ) on the valve or does the downstream system pressure exceed the valve's inlet pressure?
- Has the bleed orifice(s) in the piston become clogged with foreign material?
- Has the disc seal in the piston become worn or damaged?
- Has the valve stem become worn or damaged?
- Is the valve actually closing but leaking excessively?

### 3. Valve is leaking internally

- Is the any contamination in the fluid?
- How much is the leakage and at what pressure? If the leak is excessive it could be caused by a bent or dented pilot tube. If the leak is small, how does it compare with the factory leakage standard?
- Is the fluid chemically compatible with the seat material?
- Is the temperature of the fluid within the limits of the seat material?
- Is the valve mounted in a horizontal line with the coil on top?

4. Coil has burnt out

- Is the voltage applied correct?
- Is the voltage within +/- 10% ?
- Is the ambient temperature above 40 C (104 F)?
- Is adjacent equipment or piping radiating excessive heat to the valve or raising the air surrounding the coil above 104F?
- Is the fluid temperature above that for which the valve is rated?
- Is the valve's coil housing assembled correctly? Has the customer opened up the coil housing? Is the coil installed in the yoke(AC only)?
- Have the coil leads been cut or damaged in handling or installation?
- Is contamination or physical binding preventing the plunger from actuating? This will cause an AC coil to burn out. Monitoring the AC current draw and comparing the measured value to the holding current given in the catalog can check the presence of this condition.
- Is the cycle rate excessive?
- Is the valve mounted in an enclosure that prevents free circulation of the ambient air?
- Was the coil failure immediate or did the burnout take hours or days? If immediate, the coil may have been defective or damaged and have shorted internally.

5. Valve leaks externally

- Has the valve been disassembled? The body o-rings are frequently Teflon and may require replacement to reseal.
- Is the bonnet nut or cylinder cap adequately torqued?
- Is the fluid chemically compatible with the seal material?
- Is the temperature of the fluid within the limits of the seat material?
- 

6. Valve wears out quickly

- What is the cycle rate?
- Is the valve chattering or internal pilot stem & seat wearing rapidly (gas application)?
- Is there a regulator upstream of the valve (gas application)?
- Is the fluid contaminated with an abrasive material?
- Is the ambient or fluid temperature excessive?
- Is the fluid chemically compatible with the seal material?
- Is the temperature of the fluid within the limits of the seat material?
- What is the customer's definition of premature wear?

Contamination in fluid systems is the largest single cause of operational problems. Frequently contamination is present in new systems from sources such as pipe sealant, pipe scale, weld slag, and metallic particles from the assembly of pipe fittings. Flushing of new systems is important to reduce the occurrence of problems, however often even through flushing will not eliminate all contaminants that will break loose during the initial operation of a new system. Filters are an essential component in many systems to prevent valve problems. It is important to locate filters immediately upstream of the valves and to size the filter rating correctly. A maximum micron rating to provide adequate protection is 40 microns. Note that strainers or screens are generally not capable of providing this degree of filtration and a filter with a depth type of element is necessary.

**Standard Available Coils**

Class H coils for 31,400 Series Valves

<u>Voltage</u>	<u>Part Number</u>	<u>Resistance +/-10%</u>	<u>Inrush Amps</u>	<u>Holding Amps</u>	<u>Volt-Amps</u>
100 VAC 60 Hz	62213-10	7.36	4.3	0.75	430
110 VAC 50 Hz	62213-11	9.91	3.6	0.65	396
115 VAC 60 Hz	62213-1	9.17	3.7	0.66	426
200 VAC 60 Hz	62213-9	28.43	2.5	0.42	500
220 VAC 50 Hz	62213-12	41.50	1.5	0.26	330
230 VAC 60 Hz	62213-5	27.00	2.2	0.38	506
460 VAC 60 Hz	62213-7	111.4	1.05	0.20	483
12 VDC	62216-1	3.10		4.0	48
24 VDC	62216-2	11.53		2.0	48
48 VDC	62216-6	47.82		1.1	53
125 VDC	62216-8	238.4		0.5	63
250 VDC	62216-10	961.8		0.25	63

**OPERATION**

Opening

When voltage is applied across the coil leads a current is produced in the coil windings which generates a magnetic field. The magnetic field attracts the plunger and causes it to move toward the center of the coil or magnetic stop. Initially the plunger slides freely on the stem until it impacts the nut or shoulder at the end of the stem. The plunger's momentum is then transferred to the stem and the stem is lifted off the seat screw orifice ( This much of the action is identical to the pilot operated valves ). The stem – plunger assembly continues its motion until the shoulder on the stem contacts the piston rod link. The piston rod link is attached to the piston, so as the stem – plunger assembly completes its motion, the piston is pulled from the main valve seat effecting the full opening of the valve. In actuality, the fluid force affect the motion of the piston at pressures above approximately 5 psig and the magnetic force on the plunger ( through the mechanical connection of the stem to the plunger via the piston rod link ) is sufficient to lift the piston at lower pressures.

Closing

When voltage is removed from the coil leads, the magnetic field collapses. Gravity pulls both the plunger and stem down until the stem point seals off the orifice in the piston rod link. Fluid flow from the valve's inlet side through the bleed orifice in the piston charges the cavity above the piston to a pressure equal to the valve's inlet pressure. Since downstream pressure is acting against the center portion of the bottom of the piston, the pressure forces acting on the piston are unbalanced and act to push the piston to the closed position ( gravity and, in some valves, a piston spring assists in the closing ).

Note: In this type of valve the piston opens and closes fully independent of line pressure or system flow.

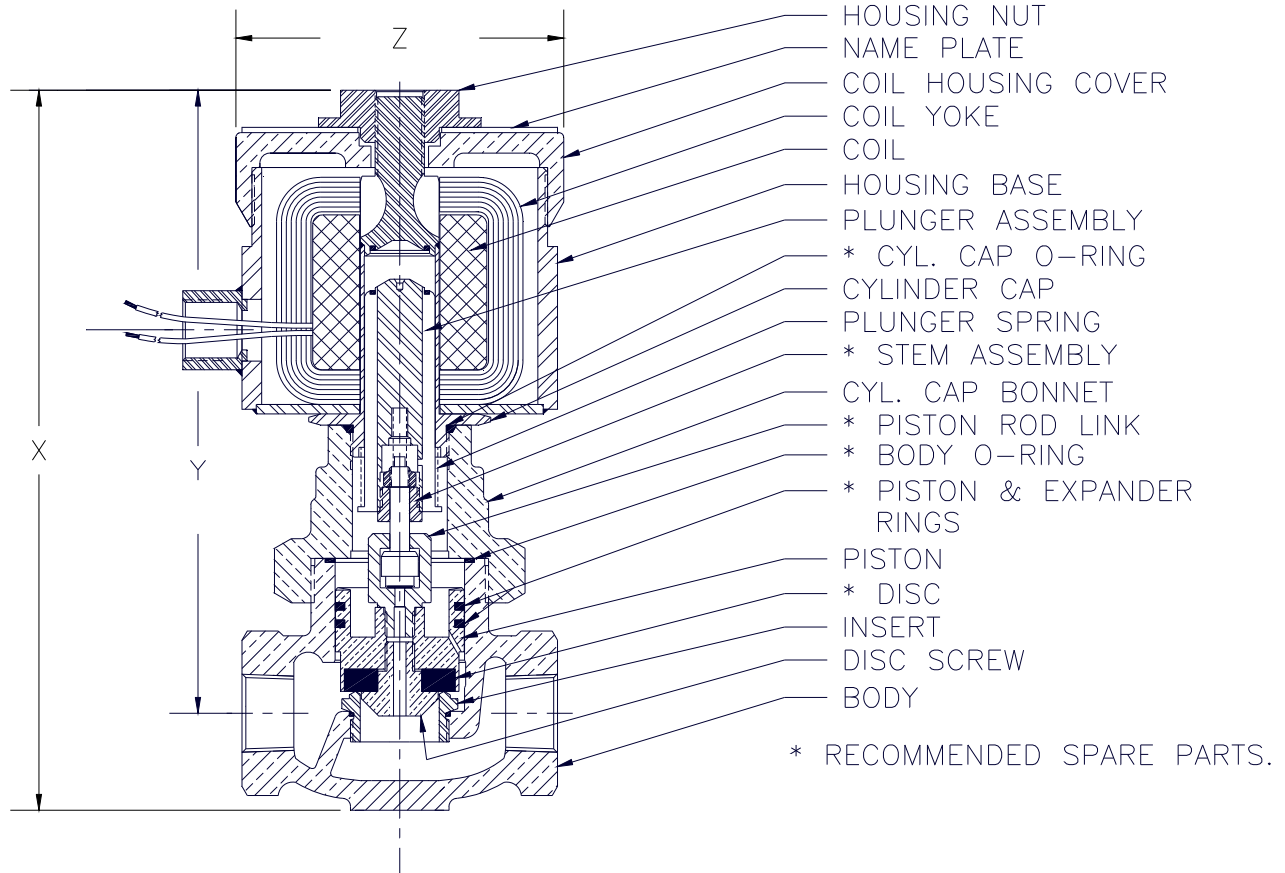

**Shown is a Model 31440 1" Bronze with a AC Coil & Explosion Proof NEMA 7 Coil Housing**

Parts that comprise standard repair kits are identified in the cross section above. Repair kit numbers are the valve model number preceded by a K/. For instance the repair kit for a 31440-200PHAA2S valve is K/31440-200PHAA2S. All other valve parts are available for repair purposes. When ordering specify the parts desired by description the complete 14 digit catalog number. If the catalog number is unavailable, and specify: 1) the valve base model, 2) the pipe size, 3) fluid, 4) operational pressure (minimum and maximum), voltage and frequency, 5) temperature if different from ambient, and 6) any special requirements.

**Dimensions, Shipping Weights, and Cv Flow Factors**

Catalog Number Prefix	Pipe Size	Main Seat Orifice Dia	<u>X</u>	<u>Y</u>	<u>Z</u>	Shipping Weight (lbs.)	<u>Cv</u>
31400	¼"	3/8"	7 7/8"	7"	2 11/16"	10	1.4
31410	3/8"	3/8"	7 7/8"	7"	2 11/16"	10	2.7
31420	½"	½"	8"	7 1/16"	3"	10	3.5
31430	¾"	1"	8 5/8"	7 3/8"	4"	12	8.4
31440	1"	1"	8 5/8"	7 3/8"	4"	12	9.5
31450	1 ¼"	1 ½"	10 1/8"	8 ¼"	5 1/16"	26	19.5
31460	1 ½"	1 ½"	10 1/8"	8 ¼"	5 1/16"	26	21.0
31570	2"	2"	13 3/16"	10 5/16"	6 1/8"	38	43.0
31580	2 ½"	3"	14 ¼"	10 3/8"	8 ½"	75	63.0
31590	3"	3"	14 ¼"	10 3/8"	8 ½"	75	71.0

**We manufacture a complete line of rugged dependable solenoid operated valves for pressure ranging from 0 to 10,000 psi.**

**Download a complete catalog of the Atkomatic Valve Product Line from <http://www.circle-seal.com/Atkomatic.html>**

**Circle Seal Controls  
Atkomatic Product  
2301 Wardlow Cir.  
Corona, CA 92880**